

SN54LS348, SN74LS348 (TIM9908)
8-LINE TO 3-LINE PRIORITY ENCODERS
WITH 3-STATE OUTPUTS
 OCTOBER 1976 — REVISED MARCH 1988

- 3-State Outputs Drive Bus Lines Directly
- Encodes 8 Data Lines to 3-Line Binary (Octal)
- Applications Include:
 N-Bit Encoding
 Code Converters and Generators
- Typical Data Delay . . . 15 ns
- Typical Power Dissipation . . . 60 mW

description

These TTL encoders feature priority decoding of the inputs to ensure that only the highest-order data line is encoded. The 'LS348 circuits encode eight data lines to three-line (4-2-1) binary (octal). Cascading circuitry (enable input E1 and enable output EO) has been provided to allow octal expansion. Outputs A0, A1, and A2 are implemented in three-state logic for easy expansion up to 64 lines without the need for external circuitry. See Typical Application Data.

FUNCTION TABLE

EI	INPUTS								OUTPUTS				
	0	1	2	3	4	5	6	7	A2	A1	A0	GS	EO
H	X	X	X	X	X	X	X	X	Z	Z	Z	H	H
L	H	H	H	H	H	H	H	H	Z	Z	Z	H	L
L	X	X	X	X	X	X	X	L	L	L	L	L	H
L	X	X	X	X	X	X	L	H	L	L	H	L	H
L	X	X	X	X	L	H	H	H	L	H	L	L	H
L	X	X	X	L	H	H	H	H	H	L	L	L	H
L	X	X	L	H	H	H	H	H	H	L	H	L	H
L	X	L	H	H	H	H	H	H	H	H	L	L	H
L	L	H	H	H	H	H	H	H	H	H	H	L	H

H = high logic level, L = low logic level, X = irrelevant
 Z = high impedance state

SN54LS348 . . . J OR W PACKAGE
 SN74LS348 . . . D OR N PACKAGE

(TOP VIEW)

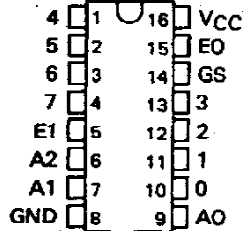

SN54LS348 . . . FK PACKAGE

(TOP VIEW)

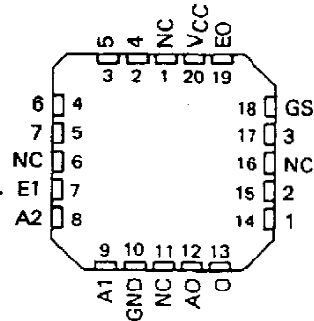

NC — No internal connection

logic symbol†

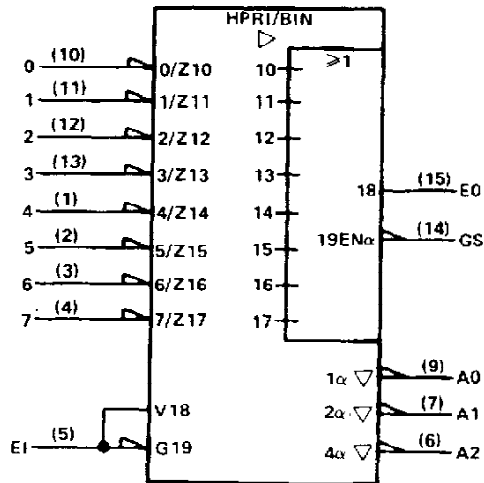

† This symbol is in accordance with ANSI/IEEE Std. 91-1984 and IEC Publication 617-12.

Pin numbers shown are for D, J, N, and W packages.

PRODUCTION DATA documents contain information current as of publication date. Products conform to specifications per the terms of Texas Instruments standard warranty. Production processing does not necessarily include testing of all parameters.



SN54LS348, SN74LS348 (TIM9908)

8-LINE TO 3-LINE PRIORITY ENCODERS WITH 3-STATE OUTPUTS

logic diagram (positive logic)

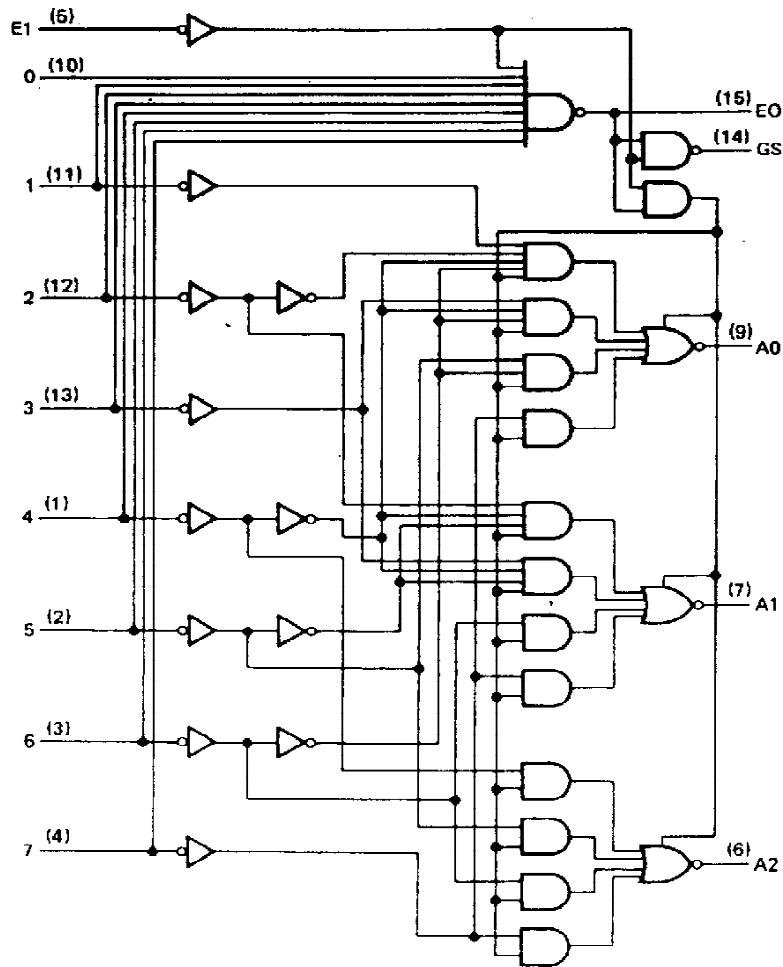

Pin numbers shown are for D, J, N, and W packages.

schematic of inputs and outputs

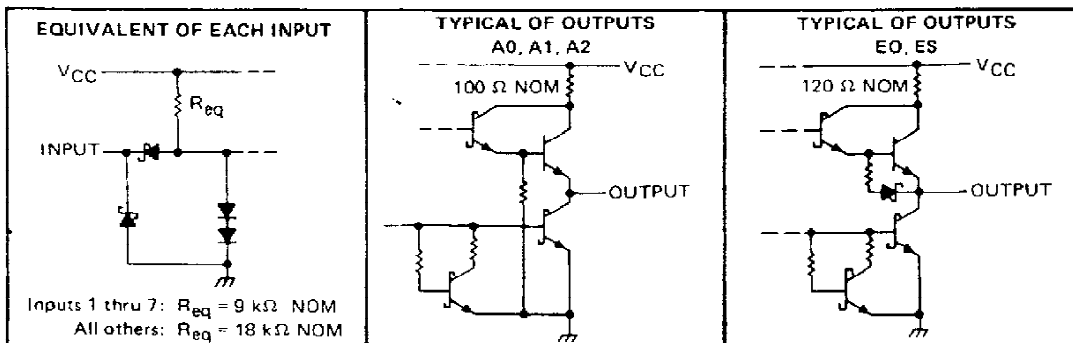

TEXAS
INSTRUMENTS

POST OFFICE BOX 655012 • DALLAS, TEXAS 75265

SN54LS348, SN74LS348 (TIM9908)

8-LINE TO 3-LINE PRIORITY ENCODERS WITH 3-STATE OUTPUTS

absolute maximum ratings over operating free-air temperature range (unless otherwise noted)

Supply voltage, V_{CC} (see Note 1)	7 V
Input voltage	7 V
Operating free-air temperature range: SN54LS348	-55°C to 125°C
SN74LS348	0°C to 70°C
Storage temperature range	-65°C to 150°C

NOTE 1: Voltage values are with respect to network ground terminal.

recommended operating conditions

	SN54LS348			SN74LS348			UNIT
	MIN	NOM	MAX	MIN	NOM	MAX	
Supply voltage, V_{CC}	4.5	5	5.5	4.75	5	5.25	V
High-level output current, I_{OH}	A0, A1, A2			-1			-2.6 mA
	EO, GS			-400			-400 μ A
Low-level output current, I_{OL}	A0, A1, A2			12			24 mA
	EO, GS			4			8 mA
Operating free-air temperature, T_A	-55		125	0		70	°C

electrical characteristics over recommended operating free-air temperature range (unless otherwise noted)

PARAMETER		TEST CONDITIONS [†]	SN54LS348		SN74LS348		UNIT	
			MIN	TYP [‡]	MAX	MIN		TYP [‡]
V_{IH}	High-level input voltage		2		2		V	
V_{IL}	Low-level input voltage		0.7		0.8		V	
V_{IK}	Input clamp voltage	$V_{CC} = \text{MIN}, I_I = -18 \text{ mA}$	-1.5		-1.5		V	
V_{OH}	High-level output voltage	A0, A1, A2	$V_{CC} = \text{MIN}, I_{OH} = -1 \text{ mA}$	2.4	3.1		V	
		EO, GS	$V_{IH} = 2 \text{ V}, I_{OH} = -2.6 \text{ mA}$			2.4 3.1		
V_{OL}	Low-level output voltage	A0, A1, A2	$V_{IL} - V_{ILmax}, I_{OH} = -400 \mu\text{A}$	2.5	3.4	2.7 3.4	V	
		EO, GS	$V_{CC} = \text{MIN}, I_{OL} = 12 \text{ mA}$	0.25	0.4	0.25 0.4		
V_{OL}	Low-level output voltage	A0, A1, A2	$V_{CC} = \text{MIN}, I_{OL} = 24 \text{ mA}$			0.35 0.5	V	
		EO, GS	$V_{IH} = 2 \text{ V}, I_{OL} = 4 \text{ mA}$	0.25	0.4	0.25 0.4		
I_{OZ}	Off-State (high-impedance state) output current	A0, A1, A2	$V_{CC} = \text{MAX}, V_O = 2.7 \text{ V}$	20		20		μ A
			$V_{IH} = 2 \text{ V}, V_O = 0.4 \text{ V}$	-20		-20		
I_I	Input current at maximum input voltage	Inputs 1 thru 7	$V_{CC} = \text{MAX}, V_I = 7 \text{ V}$	0.2		0.2		mA
		All other inputs		0.1		0.1		
I_{IH}	High-level input current	Inputs 1 thru 7	$V_{CC} = \text{MAX}, V_I = 2.7 \text{ V}$	40		40		μ A
		All other inputs		20		20		
I_{IL}	Low-level input current	Inputs 1 thru 7	$V_{CC} = \text{MAX}, V_I = 0.4 \text{ V}$	-0.8		-0.8		mA
		All other inputs		-0.4		-0.4		
I_{OS}	Short-circuit output current [§]	Outputs A0, A1, A2	$V_{CC} = \text{MAX}$	-30	-130	-30	-130	mA
		Outputs EO, GS		-20	-100	-20	-100	
I_{CC}	Supply current	$V_{CC} = \text{MAX},$ See Note 2	Condition 1	13	25	13	25	mA
			Condition 2	12	23	12	23	

[†] For conditions shown as MIN or MAX, use the appropriate value specified under recommended operating conditions.

[‡] All typical values are at $V_{CC} = 5 \text{ V}, T_A = 25^\circ \text{C}$.

[§] Not more than one output should be shorted at a time.

NOTE 2: I_{CC} (condition 1) is measured with inputs 7 and E1 grounded, other inputs and outputs open. I_{CC} (condition 2) is measured with all inputs and outputs open.



SN54LS348, SN74LS348 (TIM9908)

8-LINE TO 3-LINE PRIORITY ENCODERS WITH 3-STATE OUTPUTS

switching characteristics, $V_{CC} = 5\text{ V}$, $T_A = 25^\circ\text{C}$

PARAMETER†	FROM (INPUT)	TO (OUTPUT)	WAVEFORM	TEST CONDITIONS	MIN	TYP	MAX	UNIT
t_{PLH}	1 thru 7	A0, A1, or A2	In-phase output	$C_L = 45\text{ pF}$, $R_L = 667\ \Omega$, See Note 3		11	17	ns
t_{PHL}						20	30	
t_{PLH}	1 thru 7	A0, A1, or A2	Out-of-phase output			23	35	ns
t_{PHL}						23	35	
t_{PZH}	EI	A0, A1, or A2				25	39	ns
t_{PZL}						24	41	
t_{PLH}	0 thru 7	EO	Out-of-phase output	$C_L = 15\text{ pF}$ $R_L = 2\text{ k}\Omega$, See Note 3		11	18	ns
t_{PHL}						26	40	
t_{PLH}	0 thru 7	GS	In-phase output			38	55	ns
t_{PHL}						9	21	
t_{PLH}	EI	GS	In-phase output			11	17	ns
t_{PHL}						14	36	
t_{PLH}	EI	EO	In-phase output		17	26	ns	
t_{PHL}					25	40		
t_{PHZ}	EI	A0, A1, or A2		$C_L = 5\text{ pF}$ $R_L = 667\ \Omega$		18	27	ns
t_{PLZ}						23	35	

- † t_{PLH} = propagation delay time, low-to-high-level output
 t_{PHL} = propagation delay time, high-to-low-level output
 t_{PZH} = output enable time to high level
 t_{PZL} = output enable time to low level
 t_{PHZ} = output disable time from high level
 t_{PLZ} = output disable time from low level

NOTE 3: Load circuits and voltage waveforms are shown in Section 1.

TYPICAL APPLICATION DATA

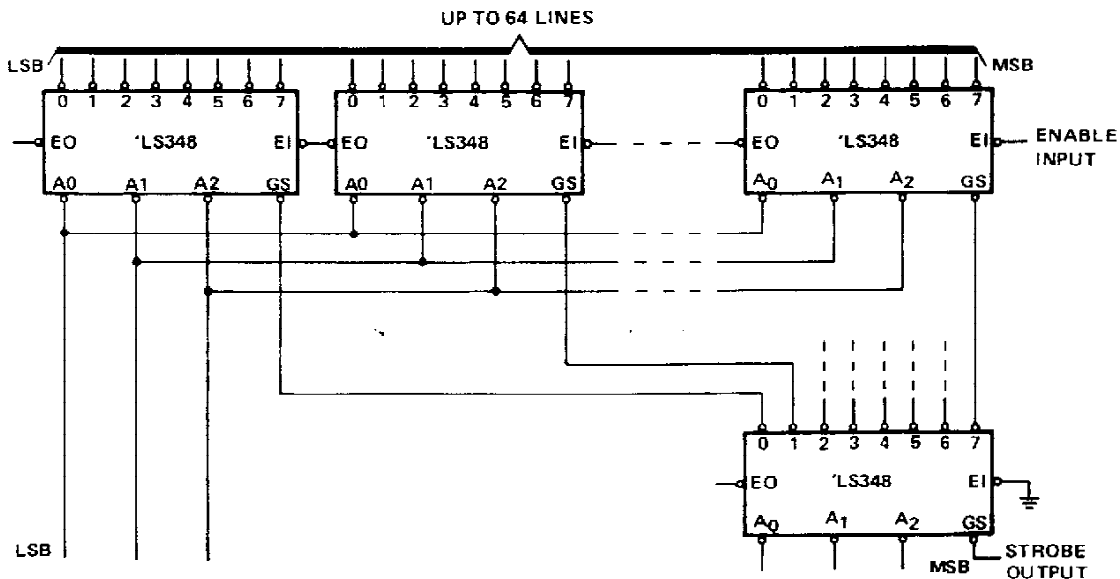

FIGURE 1—PRIORITY ENCODER WITH UP TO 64 INPUTS.

TEXAS
INSTRUMENTS

POST OFFICE BOX 655012 • DALLAS, TEXAS 75265

IMPORTANT NOTICE

Texas Instruments (TI) reserves the right to make changes to its products or to discontinue any semiconductor product or service without notice, and advises its customers to obtain the latest version of relevant information to verify, before placing orders, that the information being relied on is current.

TI warrants performance of its semiconductor products and related software to the specifications applicable at the time of sale in accordance with TI's standard warranty. Testing and other quality control techniques are utilized to the extent TI deems necessary to support this warranty. Specific testing of all parameters of each device is not necessarily performed, except those mandated by government requirements.

Certain applications using semiconductor products may involve potential risks of death, personal injury, or severe property or environmental damage ("Critical Applications").

TI SEMICONDUCTOR PRODUCTS ARE NOT DESIGNED, INTENDED, AUTHORIZED, OR WARRANTED TO BE SUITABLE FOR USE IN LIFE-SUPPORT APPLICATIONS, DEVICES OR SYSTEMS OR OTHER CRITICAL APPLICATIONS.

Inclusion of TI products in such applications is understood to be fully at the risk of the customer. Use of TI products in such applications requires the written approval of an appropriate TI officer. Questions concerning potential risk applications should be directed to TI through a local SC sales office.

In order to minimize risks associated with the customer's applications, adequate design and operating safeguards should be provided by the customer to minimize inherent or procedural hazards.

TI assumes no liability for applications assistance, customer product design, software performance, or infringement of patents or services described herein. Nor does TI warrant or represent that any license, either express or implied, is granted under any patent right, copyright, mask work right, or other intellectual property right of TI covering or relating to any combination, machine, or process in which such semiconductor products or services might be or are used.

IMPORTANT NOTICE

Texas Instruments (TI) reserves the right to make changes to its products or to discontinue any semiconductor product or service without notice, and advises its customers to obtain the latest version of relevant information to verify, before placing orders, that the information being relied on is current.

TI warrants performance of its semiconductor products and related software to the specifications applicable at the time of sale in accordance with TI's standard warranty. Testing and other quality control techniques are utilized to the extent TI deems necessary to support this warranty. Specific testing of all parameters of each device is not necessarily performed, except those mandated by government requirements.

Certain applications using semiconductor products may involve potential risks of death, personal injury, or severe property or environmental damage ("Critical Applications").

TI SEMICONDUCTOR PRODUCTS ARE NOT DESIGNED, INTENDED, AUTHORIZED, OR WARRANTED TO BE SUITABLE FOR USE IN LIFE-SUPPORT APPLICATIONS, DEVICES OR SYSTEMS OR OTHER CRITICAL APPLICATIONS.

Inclusion of TI products in such applications is understood to be fully at the risk of the customer. Use of TI products in such applications requires the written approval of an appropriate TI officer. Questions concerning potential risk applications should be directed to TI through a local SC sales office.

In order to minimize risks associated with the customer's applications, adequate design and operating safeguards should be provided by the customer to minimize inherent or procedural hazards.

TI assumes no liability for applications assistance, customer product design, software performance, or infringement of patents or services described herein. Nor does TI warrant or represent that any license, either express or implied, is granted under any patent right, copyright, mask work right, or other intellectual property right of TI covering or relating to any combination, machine, or process in which such semiconductor products or services might be or are used.

IMPORTANT NOTICE

Texas Instruments and its subsidiaries (TI) reserve the right to make changes to their products or to discontinue any product or service without notice, and advise customers to obtain the latest version of relevant information to verify, before placing orders, that information being relied on is current and complete. All products are sold subject to the terms and conditions of sale supplied at the time of order acknowledgement, including those pertaining to warranty, patent infringement, and limitation of liability.

TI warrants performance of its semiconductor products to the specifications applicable at the time of sale in accordance with TI's standard warranty. Testing and other quality control techniques are utilized to the extent TI deems necessary to support this warranty. Specific testing of all parameters of each device is not necessarily performed, except those mandated by government requirements.

CERTAIN APPLICATIONS USING SEMICONDUCTOR PRODUCTS MAY INVOLVE POTENTIAL RISKS OF DEATH, PERSONAL INJURY, OR SEVERE PROPERTY OR ENVIRONMENTAL DAMAGE ("CRITICAL APPLICATIONS"). TI SEMICONDUCTOR PRODUCTS ARE NOT DESIGNED, AUTHORIZED, OR WARRANTED TO BE SUITABLE FOR USE IN LIFE-SUPPORT DEVICES OR SYSTEMS OR OTHER CRITICAL APPLICATIONS. INCLUSION OF TI PRODUCTS IN SUCH APPLICATIONS IS UNDERSTOOD TO BE FULLY AT THE CUSTOMER'S RISK.

In order to minimize risks associated with the customer's applications, adequate design and operating safeguards must be provided by the customer to minimize inherent or procedural hazards.

TI assumes no liability for applications assistance or customer product design. TI does not warrant or represent that any license, either express or implied, is granted under any patent right, copyright, mask work right, or other intellectual property right of TI covering or relating to any combination, machine, or process in which such semiconductor products or services might be or are used. TI's publication of information regarding any third party's products or services does not constitute TI's approval, warranty or endorsement thereof.