

KW1-601CRB

DATA SHEET

QC:

ENG:

Prepared By:

Features

- ◆ 0.60" Single Digit Super Red
- ◆ Common Cathode (Common PIN 5 And PIN 10)
- ◆ Black Face, White Segment

Package Dimension:

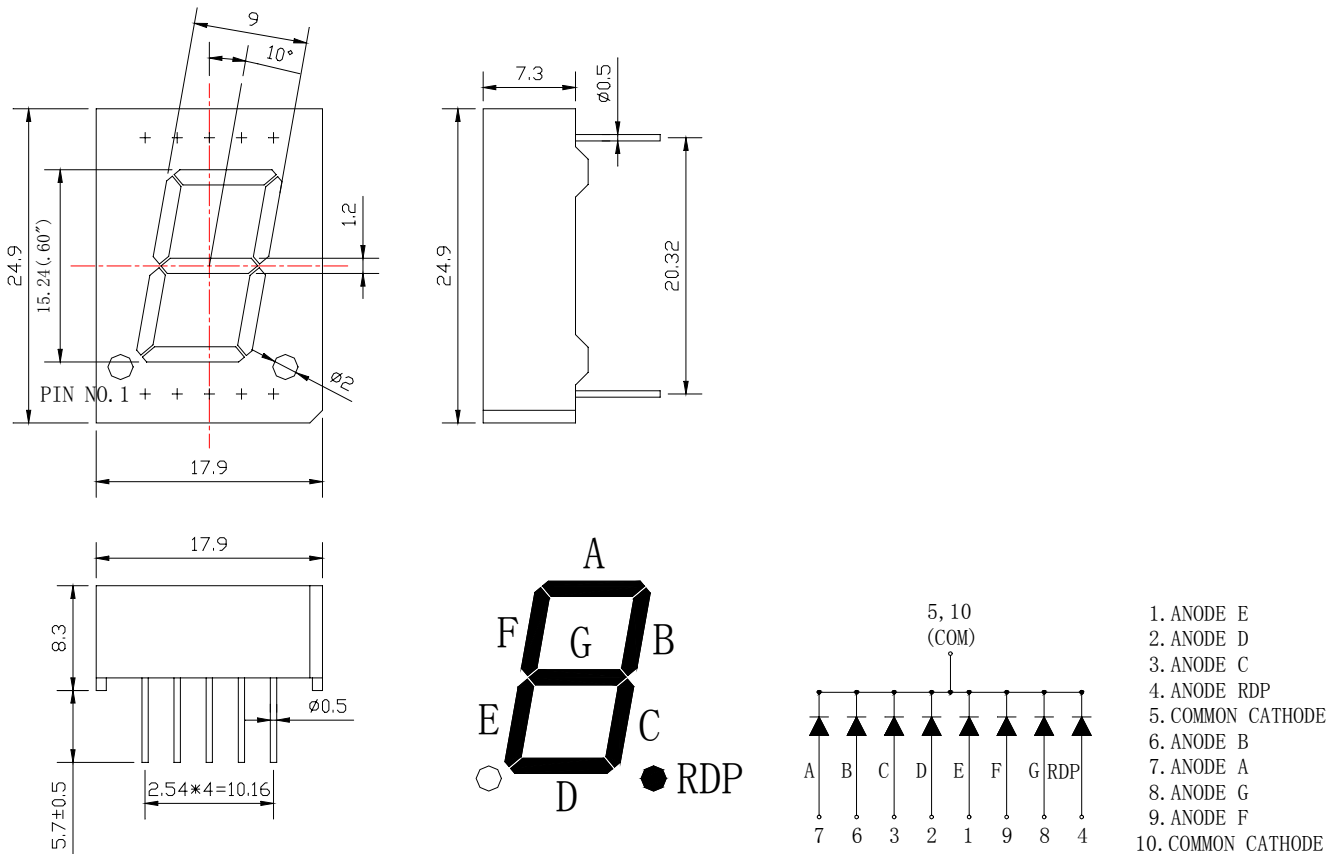

Part NO.	Face Color	Source Color
KW1-601CRB	Black/white	Red

Notes:

1. All dimensions are in millimeters (inches).
2. Tolerance is ± 0.25 (.010") mm unless otherwise noted.
3. Protruded resin under flange is 1.0mm (.04") max.
4. Lead spacing is measured where the leads emerge from the package.
5. Specifications are subject to change without notice.

Absolute Maximum Ratings at Ta=25°C

Parameter	MAX.	Unit
Power Dissipation	100	mW
Peak Forward Current (1/10 Duty Cycle, 0.1ms Pulse Width)	100	mA
Continuous Forward Current	50	mA
Derating Linear From 50°C	0.4	mA/°C
Reverse Voltage	5	V
Operating Temperature Range	-40°C to +80°C	
Storage Temperature Range	-40°C to +80°C	
Lead Soldering Temperature [4mm(.157") From Body]	260°C for 5 Seconds	

Electrical Optical Characteristics at Ta=25°C

Parameter	Symbol	Min.	Typ.	Max.	Unit	Test Condition
Luminous Intensity	I _v	0.4	0.58	---	mcd	I _F =20mA (Note 1)
Viewing Angle	2θ _{1/2}	---	---	---	Deg	(Note 2)
Peak Emission Wavelength	λ _p	695	700	705	nm	I _F =20mA
Dominant Wavelength	λ _d	---	697	---	nm	I _F =20mA (Note 3)
Spectral Line Half-Width	Δλ	24	29	34	nm	I _F =20mA
Forward Voltage	V _F	---	2.1	2.8	V	I _F =20mA
Reverse Current	I _R	---	---	100	μA	V _R =5V

Note:

- Luminous intensity is measured with a light sensor and filter combination that approximates the CIE eye-response curve.
- θ_{1/2} is the off-axis angle at which the luminous intensity is half the axial luminous intensity.
- The dominant wavelength (λ_d) is derived from the CIE chromaticity diagram and represents the single wavelength which defines the color of the device.

Typical Electrical / Optical Characteristics Curves
 (25°C Ambient Temperature Unless Otherwise Noted)

Spectral Radiance (Peak @ 700nm)

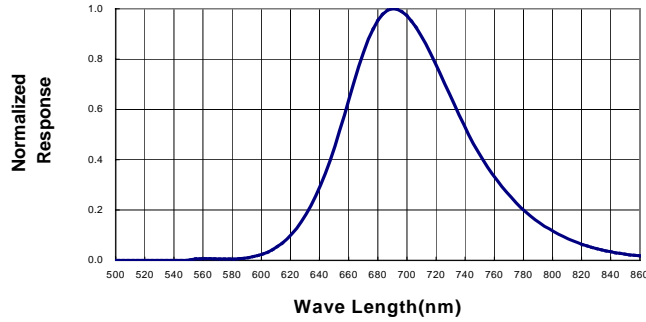

Relative Luminous Intensity vs Forward Current

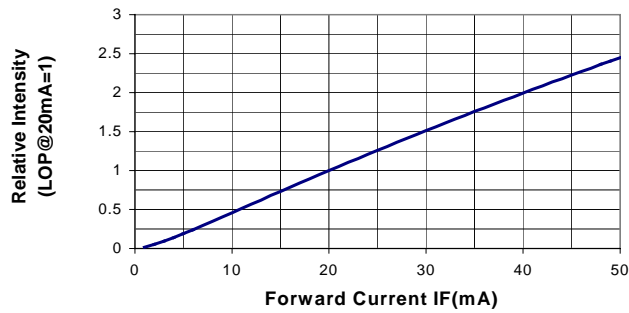

Forward Current vs Forward Voltage

