

## Features

- High intensity
- Wide viewing angle
- General purpose leads
- Reliable and rugged

## Absolute Maximum Ratings at Ta=25

Parameter	Max.	Unit
Power Dissipation	100	mW
Peak Forward Current (1/10 Duty Cycle, 0.1ms Pulse Width)	100	mA
Continuous Forward Current	40	mA
Derating Linear From 50	0.4	mA /
Reverse Voltage	5	V
Operating Temperature Range	-40 to +80	
Storage Temperature Range	-40 to +80	
Lead Soldering Temperature [4mm(.157") From Body]	260 for 5 Seconds	

### Notes:

1. All dimensions are in millimeters (inches).
2. Protruded resin under flange is 1.0mm (.04") max.
3. Lead spacing is measured where the leads emerge from the package.
4. Specifications are subject to change without notice.

## Package Dimensions

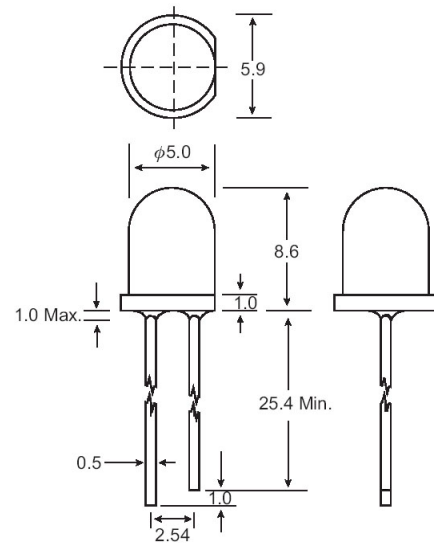

Unit: mm (inches)

Tolerance:  $\pm 0.25\text{mm}$  (.010") max

Part No.	Emitted Color	Lens Color	Peak Wavelength $\lambda_p$ (nm)	Vf (V) $I_f = 20\text{mA}$ (Note E1)		Iv (mcd) (Note E2)		Viewing Angle $2\theta_{1/2}$ (Deg) (Note E3)
				Min	Typ	Min	Typ	
EL-5R631	Red	Red Diffused	660	1.6	1.8	15	35	60
EL-5G631	Green	Green Diffused	568	1.7	2.2	4.0	18	60
EL-5Y631	Yellow	Yellow Diffused	590	1.6	2.1	15	30	60
EL-5R232	Red	Water Clear	660	1.6	1.8	60	80	20
EL-5G232	Green	Water Clear	568	1.7	2.2	18	60	20
EL-5Y232	Yellow	Water Clear	590	1.6	2.1	35	55	20
EL-5R233	Red	Red Transparent	660	1.6	1.8	50	90	20
EL-5G233	Green	Green Transparent	568	1.7	2.2	18	60	20
EL-5Y233	Yellow	Yellow Transparent	590	1.6	2.1	35	55	20

### Parameter

Luminous Intensity

Dominant Wavelength

Peak Emission Wavelength

Viewing Angle

Spectral Line Half-Width

Forward Voltage

Reverse Current

### Test Condition

$I_f = 20\text{mA}$  (Note E1. Luminous intensity is measured with a light sensor and filter combination that approximates the CIE eye-response curve.)

$I_f = 20\text{mA}$  (Note E2: The dominant wavelength ( $\lambda_d$ ) is derived from the CIE chromaticity diagram and represents the single wavelength which defines the color of the device.)

$I_f = 20\text{mA}$

(Note E3.  $_{1/2}$  is the off-axis angle at which the luminous intensity is half the axial luminous intensity.)

$I_f = 20\text{mA}$

$I_f = 20\text{mA}$

$I_f = 20\text{mA}$