

Features

- High intensity
- Wide viewing angle
- General purpose leads
- Reliable and rugged

Absolute Maximum Ratings at Ta=25°C

| Parameter | Max. | Unit |
|--|---------------------|---------|
| Power Dissipation | 100 | mW |
| Peak Forward Current (1/10 Duty Cycle, 0.1ms Pulse Width) | 100 | mA |
| Continuous Forward Current | 40 | mA |
| Derating Linear From 50°C | 0.4 | mA / °C |
| Reverse Voltage | 5 | V |
| Operating Temperature Range | -40°C to +80°C | |
| Storage Temperature Range | -40°C to +80°C | |
| Lead Soldering Temperature [4mm(.157") From Body] | 260°C for 5 Seconds | |

Notes:

1. All dimensions are in millimeters (inches).
2. Protruded resin under flange is 1.0mm (.04") max.
3. Lead spacing is measured where the leads emerge from the package.
4. Specifications are subject to change without notice.

Package Dimensions

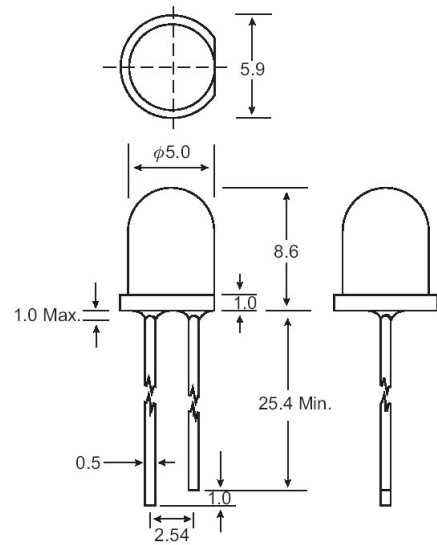

Unit: mm (inches)

Tolerance: ±0.25mm (.010") max

| Part No. | Emitted Color | Lens Color | Peak Wavelength λ_p (nm) | Vf (V) $I_f = 20\text{mA}$ (Note E1) | | Iv (mcd) (Note E2) | | Viewing Angle $2\theta_{1/2}$ (Deg) (Note E3) |
|-----------|--------------------|----------------|-------------------------------------|--|-----|-----------------------|-----|---|
| | | | | Min | Typ | Min | Typ | |
| EL-5AR252 | Ultra-Amber Red | Water Clear | 645 | 1.8 – 2.3 | | 4500 – 9000 | | 18 |
| EL-5SY252 | Ultra-Yellow | Water Clear | 596 | 1.8 – 2.25 | | 6000 – 12000 | | 18 |
| EL-5PG252 | Ultra-Pure Green | Water Clear | 525 | 2.8 – 3.6 | | 2300 – 5500 | | 18 |
| EL-5BG252 | Ultra-Bluish Green | Water Clear | 508 | 2.8 – 3.6 | | 4500 – 6500 | | 18 |
| EL-5B252 | Ultra-Blue | Water Clear | 470 | 2.8 – 3.6 | | 1500 – 2500 | | 18 |
| EL-5B242 | Super-Blue | Water Clear | 468 | 2.8 – 3.6 | | 1000 – 1500 | | 18 |
| EL-5W252 | Ultra-White | Water Clear | X-0.28, Y-0.28 | 2.8 – 3.6 | | 1500 – 7000 | | 18 |
| EL-5W654 | Ultra-White | White Diffused | X-0.28, Y-0.28 | 2.8 – 3.6 | | 1200 – 2500 | | 60 |

Parameter

Luminous Intensity

Dominant Wavelength

Peak Emission Wavelength

Viewing Angle

Spectral Line Half-Width

Forward Voltage

Reverse Current

Test Condition

$I_f = 20\text{mA}$ (Note E1. Luminous intensity is measured with a light sensor and filter combination that approximates the CIE eye-response curve.)

$I_f = 20\text{mA}$ (Note E2: The dominant wavelength (λ_d) is derived from the CIE chromaticity diagram and represents the single wavelength which defines the color of the device.)

$I_f = 20\text{mA}$

(Note E3. $\theta_{1/2}$ is the off-axis angle at which the luminous intensity is half the axial luminous intensity.)

$I_f = 20\text{mA}$

$I_f = 20\text{mA}$

$I_f = 20\text{mA}$