

Features

- High intensity
- Wide viewing angle
- General purpose leads
- Reliable and rugged

Absolute Maximum Ratings at Ta=25°C

Parameter	Max.	Unit
Power Dissipation	100	mW
Peak Forward Current (1/10 Duty Cycle, 0.1ms Pulse Width)	100	mA
Continuous Forward Current	40	mA
Derating Linear From 50°C	0.4	mA / °C
Reverse Voltage	5	V
Operating Temperature Range	-40°C to +80°C	
Storage Temperature Range	-40°C to +80°C	
Lead Soldering Temperature [4mm(.157") From Body]	260°C for 5 Seconds	

Notes:

1. All dimensions are in millimeters (inches).
2. Protruded resin under flange is 1.0mm (.04") max.
3. Lead spacing is measured where the leads emerge from the package.
4. Specifications are subject to change without notice.

Package Dimensions

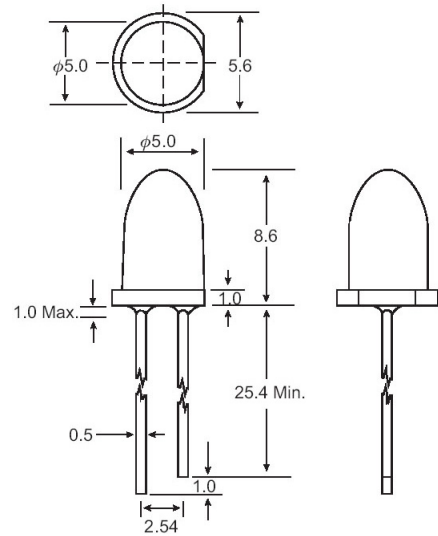

Unit: mm (inches)

Tolerance: ±0.25mm (.010") max

(Ta=25°C)

Part No.	Emitting Color	Lens Color	Peak Wavelength λ_p (nm)	Vf (V) $I_f = 20\text{mA}$ (Note E1)		Iv (mcd) (Note E2)		Viewing Angle $2\theta_{1/2}$ (Deg) (Note E3)
				Min	Typ	Min	Typ	
EL-5R241-B4	Red	Red Diffused	660	1.6	1.8	250	550	18
EL-5G241-B4	Green	Green Diffused	568	1.7	2.2	55	140	18
EL-5Y241-B4	Yellow	Yellow Diffused	588	1.7	2.0	220	500	18
EL-5O241-B4	Orange	Orange Diffused	610	1.7	2.1	200	450	18
EL-5R142-B4	Red	Water Clear	660	1.6	1.8	180	850	15
EL-5G142-B4	Green	Water Clear	568	1.7	2.2	150	400	15
EL-5Y142-B4	Yellow	Water Clear	588	1.7	2.0	350	900	15
EL-5O142-B4	Orange	Water Clear	610	1.7	2.1	180	450	15
EL-5R143-B4	Red	Red Transparent	660	1.6	1.8	150	850	15
EL-5G143-B4	Green	Green Transparent	568	1.7	2.2	120	400	15
EL-5Y143-B4	Yellow	Yellow Transparent	588	1.7	2.0	300	900	15

Parameter

Luminous Intensity

Viewing Angle

Peak Emission Wavelength

Dominant Wavelength

Spectral Line Half-Width

Forward Voltage

Reverse Current

Test Condition

$I_f = 20\text{mA}$ (Note E1. Luminous intensity is measured with a light sensor and filter combination that approximates the CIE eye-response curve.)

(Note E2. $\theta_{1/2}$ is the off-axis angle at which the luminous intensity is half the axial luminous intensity.)

$I_f = 20\text{mA}$

$I_f = 20\text{mA}$ (Note E3: The dominant wavelength (λ_d) is derived from the CIE chromaticity diagram and represents the single wavelength which defines the color of the device.)

$I_f = 20\text{mA}$

$I_f = 20\text{mA}$

$I_f = 20\text{mA}$