

## Features

- High intensity
- Wide viewing angle
- General purpose leads
- Reliable and rugged

## Absolute Maximum Ratings at Ta=25°C

| Parameter  | Max.                | Unit    |
|--|---------------------|---------|
| Power Dissipation  | 100                 | mW      |
| Peak Forward Current<br>(1/10 Duty Cycle, 0.1ms Pulse Width) | 100                 | mA      |
| Continuous Forward Current                                   | 40                  | mA      |
| Derating Linear From 50°C                                    | 0.4                 | mA / °C |
| Reverse Voltage  | 5                   | V       |
| Operating Temperature Range                                  | -40°C to +80°C      |         |
| Storage Temperature Range                                    | -40°C to +80°C      |         |
| Lead Soldering Temperature<br>[4mm(.157") From Body]         | 260°C for 5 Seconds |         |

### Notes:

1. All dimensions are in millimeters (inches).
2. Protruded resin under flange is 1.0mm (.04") max.
3. Lead spacing is measured where the leads emerge from the package.
4. Specifications are subject to change without notice.

## Package Dimensions

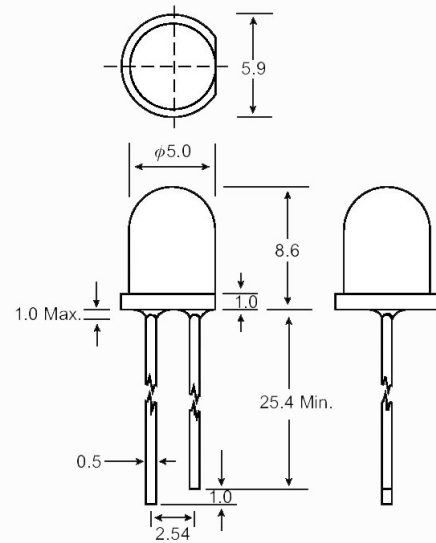

Unit: mm (inches)

Tolerance: ±0.25mm (.010") max

(Ta=25°C)

| Part No. | Emitting Color | Lens Color         | Peak Wavelength λp (nm) | Vf (V)<br>If = 20mA<br>(Note E1) |     | Iv (mcd)<br>(Note E2) |     | Viewing Angle<br>2θ <sub>1/2</sub> (Deg)<br>(Note E3) |
|----------|----------------|--------------------|-------------------------|----------------------------------|-----|-----------------------|-----|---|
|          |                |                    |                         | Min                              | Typ | Min                   | Typ |   |
| EL-5R641 | Red            | Red Diffused       | 660                     | 1.6 – 1.8                        |     | 200 – 450             |     | 60  |
| EL-5G641 | Green          | Green Diffused     | 568                     | 1.7 – 2.2                        |     | 35 – 120              |     | 60  |
| EL-5Y641 | Yellow         | Yellow Diffused    | 588                     | 1.7 – 2.0                        |     | 200 – 500             |     | 60  |
| EL-5O641 | Orange         | Orange Diffused    | 610                     | 1.7 – 2.1                        |     | 180 – 450             |     | 60  |
| EL-5R242 | Red            | Water Clear        | 660                     | 1.6 – 1.8                        |     | 150 – 850             |     | 20  |
| EL-5G242 | Green          | Water Clear        | 568                     | 1.7 – 2.2                        |     | 120 – 450             |     | 20  |
| EL-5Y242 | Yellow         | Water Clear        | 588                     | 1.7 – 2.0                        |     | 300 – 900             |     | 20  |
| EL-5O242 | Orange         | Water Clear        | 610                     | 1.7 – 2.1                        |     | 180 – 450             |     | 20  |
| EL-5R243 | Red            | Red Transparent    | 660                     | 1.6 – 1.8                        |     | 150 – 850             |     | 20  |
| EL-5G243 | Green          | Green Transparent  | 568                     | 1.7 – 2.2                        |     | 120 – 400             |     | 20  |
| EL-5Y243 | Yellow         | Yellow Transparent | 588                     | 1.7 – 2.0                        |     | 300 – 900             |     | 20  |

### Parameter

Luminous Intensity

Viewing Angle

Peak Emission Wavelength

Dominant Wavelength

Spectral Line Half-Width

Forward Voltage

Reverse Current

### Test Condition

If = 20mA (Note E1. Luminous intensity is measured with a light sensor and filter combination that approximates the CIE eye-response curve.)

(Note E2. θ<sub>1/2</sub> is the off-axis angle at which the luminous intensity is half the axial luminous intensity.)

If = 20mA

If = 20mA (Note E3: The dominant wavelength (λ<sub>d</sub>) is derived from the CIE chromaticity diagram and represents the single wavelength which defines the color of the device.)

If = 20mA

If = 20mA

If = 20mA