

Features

- High intensity
- Wide viewing angle
- General purpose leads
- Reliable and rugged

Package Dimensions

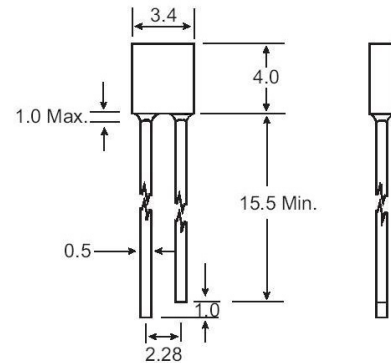
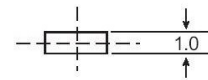

Absolute Maximum Ratings at Ta=25°C

Parameter	Max.	Unit
Power Dissipation	100	mW
Peak Forward Current (1/10 Duty Cycle, 0.1ms Pulse Width)	100	mA
Continuous Forward Current	40	mA
Derating Linear From 50°C	0.4	mA / °C
Reverse Voltage	5	V
Operating Temperature Range	-40°C to +80°C	
Storage Temperature Range	-40°C to +80°C	
Lead Soldering Temperature [4mm(.157") From Body]	260°C for 5 Seconds	

Notes:

1. All dimensions are in millimeters (inches).
2. Protruded resin under flange is 1.0mm (.04") max.
3. Lead spacing is measured where the leads emerge from the package.
4. Specifications are subject to change without notice.

Unit: mm (inches)

Tolerance: ± 0.25mm (.010") max.

Part No.	Emitting Color	Lens Color	Peak Wavelength λ_p (nm)	Vf (V) $I_f = 20\text{mA}$ (Note E1)		Iv (mcd) (Note E2)		Viewing Angle $2\theta_{1/2}$ (Deg) (Note E3)
				Min	Typ	Min	Typ	
EL-13RX31	Red	Red Diffused	660	1.7 - 2.0		5.0 - 10		160
EL-13GX31	Green	Green Diffused	570	1.7 - 2.2		2.5 - 4.0		160
EL-13YX31	Yellow	Yellow Diffused	590	1.7 - 2.0		7.0 - 14		160
EL-13RU32	Red	Water Clear	660	1.7 - 2.0		10 - 25		100
EL-13GU32	Green	Water Clear	570	1.7 - 2.2		5.0 - 10		100
EL-13YU32	Yellow	Water Clear	590	1.7 - 2.0		25 - 35		100
EL-13RU33	Red	Red Transparent	660	1.7 - 2.0		10 - 25		100
EL-13GU33	Green	Green Transparent	570	1.7 - 2.2		5.0 - 10		100
EL-13YU33	Yellow	Yellow Transparent	590	1.7 - 2.0		25 - 35		100

Parameter

Luminous Intensity

Dominant Wavelength

Peak Emission Wavelength

Viewing Angle

Spectral Line Half-Width

Forward Voltage

Reverse Current

Test Condition

$I_f = 20\text{mA}$ (Note E1. Luminous intensity is measured with a light sensor and filter combination that approximates the CIE eye-response curve.)

$I_f = 20\text{mA}$ (Note E2: The dominant wavelength (λ_d) is derived from the CIE chromaticity diagram and represents the single wavelength which defines the color of the device.)

$I_f = 20\text{mA}$

(Note E3. $\theta_{1/2}$ is the off-axis angle at which the luminous intensity is half the axial luminous intensity.)

$I_f = 20\text{mA}$

$I_f = 20\text{mA}$

$I_f = 20\text{mA}$