

LL-503IRC2E-013

**DATA SHEET**

QC:

ENG:

Prepared By:

## Features

- ◆ Standard T-1 3/4 diameter package
- ◆ Wide viewing angle
- ◆ Infrared Emitting Diode
- ◆ Reliable and rugged

## Package Dimension:

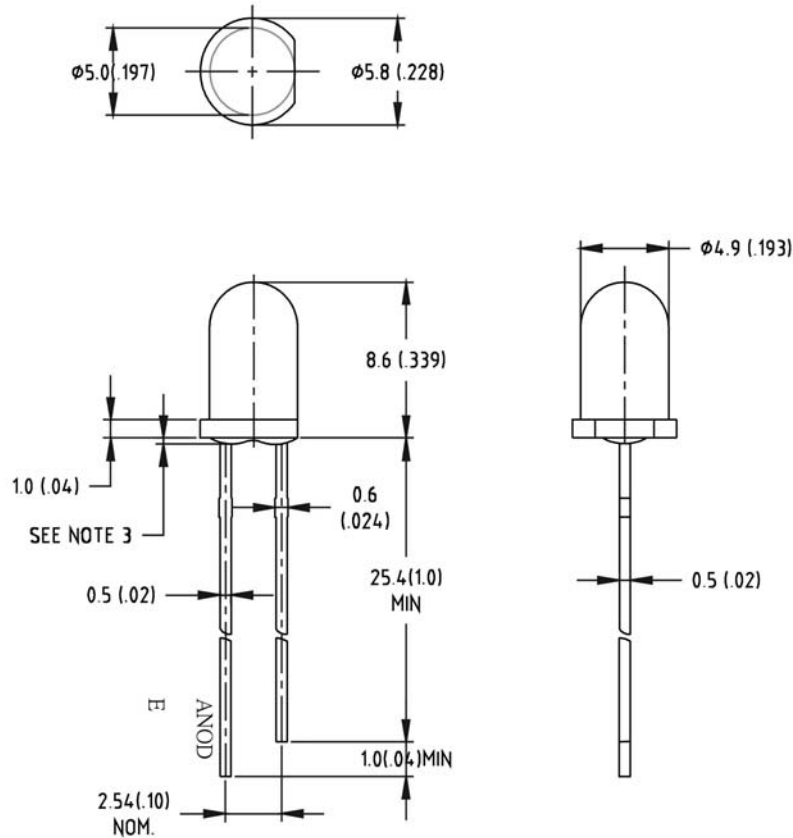

Part NO.	Lens Color	Source Color
LL-503IRC2E-013	Water Clear	Infrared

### Notes:

1. All dimensions are in millimeters (inches).
2. Tolerance is  $\pm 0.25$  (.010") mm unless otherwise noted.
3. Protruded resin under flange is 1.0mm(.04") max
4. Lead spacing is measured where the leads emerge from the package.
5. Specifications are subject to change without notice

**Absolute Maximum Ratings at Ta=25°C**

Parameter	MAX.	Unit
Power Dissipation	100	mW
Peak Forward Current (1/10 Duty Cycle, 0.1ms Pulse Width)	100	mA
Continuous Forward Current	35	mA
Reverse Voltage	5	V
Operating Temperature Range	-40°C to +80°C	
Storage Temperature Range	-40°C to +80°C	
Lead Soldering Temperature [4mm(.157") From Body]	260°C for 5 Seconds	

**Electrical Optical Characteristics at Ta=25°C**

Parameter	Symbol	Min.	Typ.	Max.	Unit	Test Condition
Radiant Intensity	I <sub>e</sub>	---	18	---	mW/Sr	I <sub>F</sub> =20mA
Viewing Angle	2θ <sub>1/2</sub>	---	45	---	Deg	Note 1
Peak Emission Wavelength	λ <sub>p</sub>	---	940	---	nm	I <sub>F</sub> =20mA
Spectral Line Half-Width	Δλ	---	60	---	nm	I <sub>F</sub> =20mA
Forward Voltage	V <sub>F</sub>	---	1.2	1.5	V	I <sub>F</sub> =20mA
Reverse Current	I <sub>R</sub>	---	---	100	μA	V <sub>R</sub> =5V

**Note:**

1. θ<sub>1/2</sub> is the off-axis angle at which the luminous intensity is half the axial luminous intensity.

Typical Electrical / Optical Characteristics Curves  
 (25°C Ambient Temperature Unless Otherwise Noted)

**Spectral Radiance (Peak @ 940nm)**

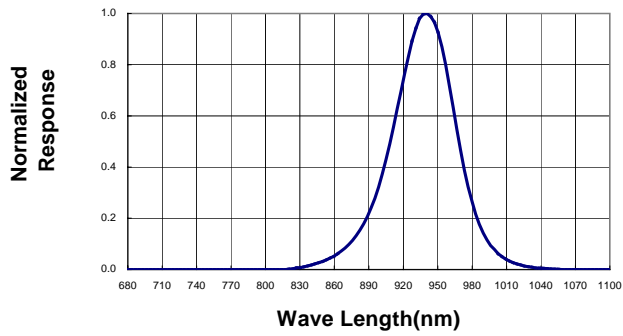

**Forward Current vs Forward Voltage**

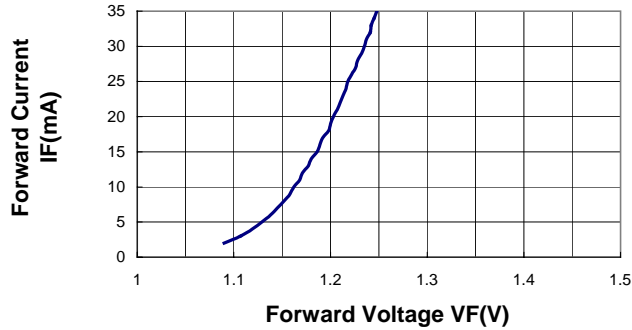

**Relative Luminous Intensity vs Forward Current**

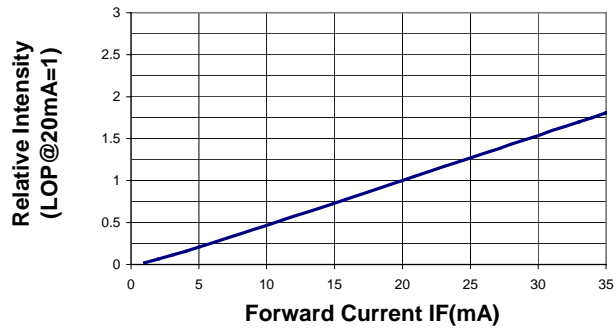

**Beam Pattern**

