

NAIS

250 mW Slim Power Relay

LK-S RELAYS

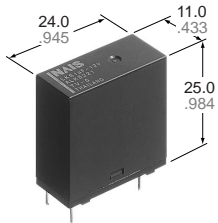

mm inch

FEATURES

1. High sensitivity: 250mW

The power-saving relay is highly sensitive at the nominal operating power of 250 mW 530 mW power consumption on LK relays).

2. High insulation resistance between contact and coil

- 1) Creepage distance and clearances between contact and coil: Min. 6 mm .236 inch (In compliance with IEC65)
- 2) Surge withstand voltage between contact and coil: 10,000 V

3. High noise immunity realized by the card separation structure between contact and coil

4. Popular terminal pitch in AV equipment field

5. Space-saving slim type

Base area: Width 11 × Length 24 mm
Width .433 × Length .945 inch

6. Conforms to the various safety standards

UL/CSA, VDE, TÜV and SEMKO SEV approved

SPECIFICATIONS

Contact

Arrangement	1 Form A	
Initial contact resistance, max. (By voltage drop 6 V DC 1 A)	Max. 100 mΩ	
Contact material	Silver alloy	
Rating (resistive load)	Nominal switching capacity	5 A 277 V AC
	Max. switching power	1,385 V A
	Max. switching voltage	277 V AC
Expected life (min. operations)	Max. switching current	5 A (AC)
	Mechanical (at 180 cpm)	10 ⁶
Electrical (at 20 cpm) (at rated load)		10 ⁵

Coil

Nominal operating power	250 mW
-------------------------	--------

Remarks

- * Specifications will vary with foreign standards certification ratings.
- *1 Measurement at same location as "Initial breakdown voltage" section.
- *2 Detection current: 10mA
- *3 Wave is standard shock voltage of $\pm 1.2 \times 50\mu s$ according to JEC-212-1981
- *4 Excluding contact bounce time.
- *5 Half-wave pulse of sine wave: 11 ms; detection time: 10 μs
- *6 Half-wave pulse of sine wave: 6 ms
- *7 Detection time: 10 μs
- *8 Refer to 5. Conditions for operation, transport and storage mentioned in AMBIENT ENVIRONMENT (Page 61).

Characteristics

Max. operating speed	20 cpm (at rated load)	
Initial insulation resistance*1	Min. 1,000 MΩ (at 500 V DC)	
Initial *2 breakdown voltage	Between open contacts	1,000 Vrms for 1 min.
	Between contact and coil	4,000 Vrms for 1 min.
Initial surge voltage between contact and coil*3	Min. 10,000 V	
Operate time*4 (at nominal voltage)	Approx. 7 ms (at 20°C 68°F)	
Release time (with diode)*4 (at nominal voltage)	Approx. 2 ms (at 20°C 68°F)	
Temperature rise (at 70°C)	Max. 35°C with nominal coil voltage and at 5 A contact carrying current (resistance method)	
Shock resistance	Functional*5	Min. 200 m/s ² {approx. 20 G}
	Destructive*6	Min. 1,000 m/s ² {approx. 100 G}
Vibration resistance	Functional*7	10 to 55Hz at double amplitude of 1.5mm
	Destructive	10 to 55Hz at double amplitude of 1.5mm
Conditions for operation, transport and storage*8 (Not freezing and condensing at low temperature)	Ambient temp.	-40°C to +70°C -40°F to +158°F
	Humidity	5 to 85% R.H.
	Air pressure	86 to 106 kPa
Unit weight	Approx. 12 g .42 oz	

TYPICAL APPLICATIONS

- Audio visual equipment
- Office equipment
- Home appliances

ORDERING INFORMATION

Ex. LKS 1a F - 12V

Contact arrangement	Protective construction	Coil voltage(DC)
1a: 1 Form A	F: Flux-resistant type	5, 9, 12, 24V

UL/CSA, TÜV, SEMKO, TV-5 approved type is standard.

- Notes 1. Standard packing Carton: 100 pcs. Case: 500 pcs.
2. 6 V, 18 V DC types are also available. Please consult us for details.

TYPES AND COIL DATA (at 20°C 68°F)

Part No.	Nominal voltage, V DC	Pick-up voltage, V DC (max.) (Initial)	Drop-out voltage, V DC (min.) (Initial)	Coil resistance, Ω (±10%)	Nominal operating current, mA (±10%)	Nominal operating power, mW	Maximum allowable voltage, V DC (at 20°C 68°F)
LKS1aF-5V	5	3.5	0.5	100	50	250	6.5
LKS1aF-9V	9	6.3	0.9	324	27.8	250	11.7
LKS1aF-12V	12	8.4	1.2	576	20.8	250	15.6
LKS1aF-24V	24	16.8	2.4	2,304	10.4	250	31.2

DIMENSIONS

mm inch

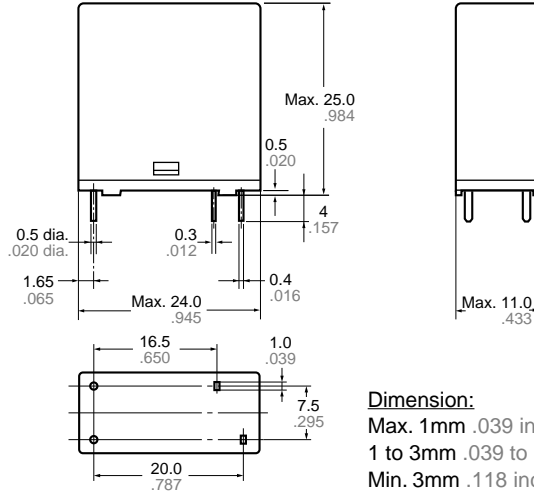

PC board pattern (Bottom view)

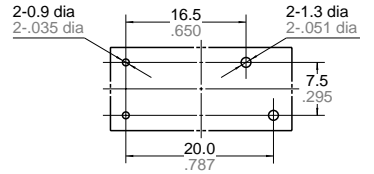

Tolerance: ±0.1 ±.004

Schematic (Bottom view)



REFERENCE DATA

1. Max. switching power (AC resistive load)

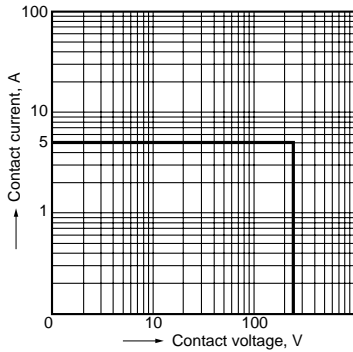

2. Coil temperature rise

Sample: LKS1aF-12V, 6 pcs.
Point measured: coil inside
Contact current: 0 A, 5A

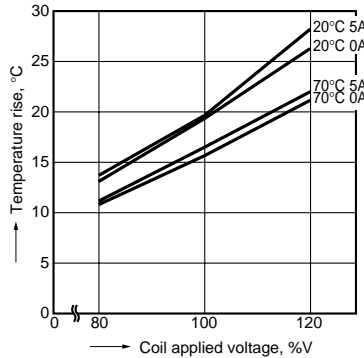

3. Ambient temperature characteristics and coil applied voltage

Contact current: 5 A

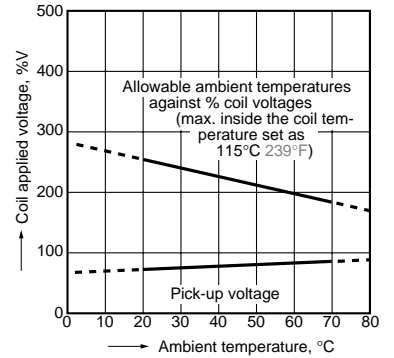

4. Life curve

Operation frequency: 20 times/min.
(ON/OFF = 1.5s: 1.5s)

Ambient temperature: Room temperature

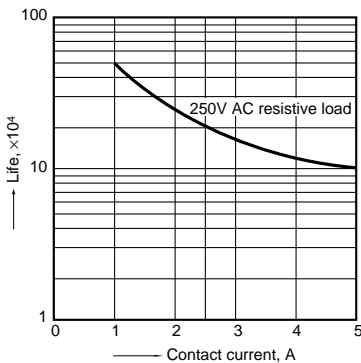

LK-S

5-(1). Electrical life test

(5 A 250 V AC, resistive load)

Sample: LKS1aF-12V, 6 pcs.

Operation frequency: 20 times/min.

(ON/OFF = 1.5s: 1.5s)

Ambient temperature: 20°C 68°F

Circuit:

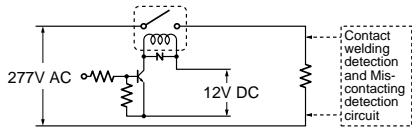

Change of pick-up and drop-out voltage

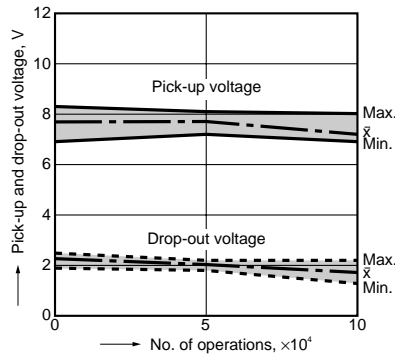

Change of contact resistance

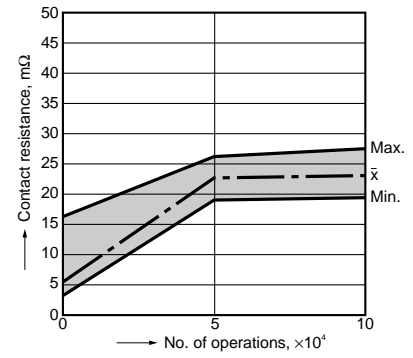

5-(2). Electrical life test (UL lamp load test TV-5)

Tested sample: LKS1aF-12V, 6 pcs.

• Overload test

Load: 7.5 A 120 V AC (60 Hz),

Inrush: 111 A

Operation frequency: 10 times/min

(ON: OFF = 1 s: 5 s)

No. of operations: 50 ope.

• Endurance test

Load: 5A 120 V AC (60 Hz),

Inrush: 78 A

Operation frequency: 10 times/min

(ON: OFF = 1 s: 5 s)

No. of operations: 25,000 ope.

Change of pick-up and drop-out voltage

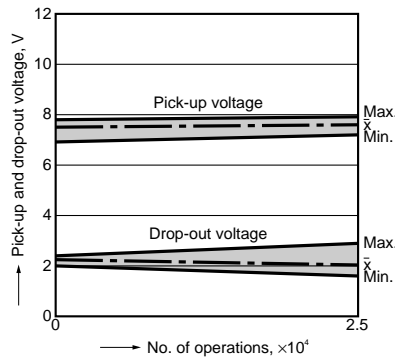

Change of contact resistance

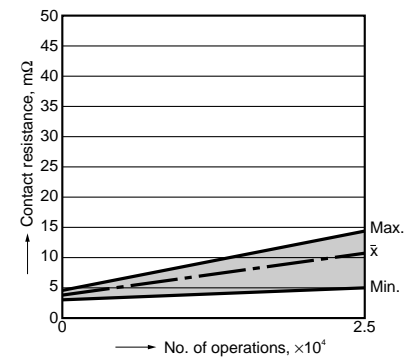

For Cautions for Use, see Relay Technical Information (Page 48 to 76).