

NAIS

AQ1 SOLID STATE RELAY

AQ1-RELAYS

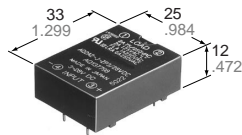
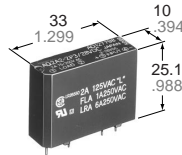
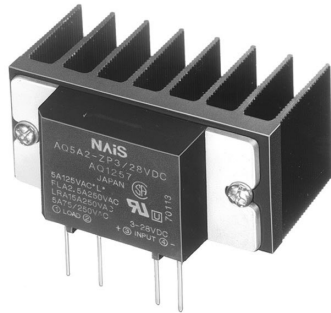

mm inch

FEATURES

- Strong against high inrush current and long life
- Strong against high inrush current and long life
- Optical isolation: 5×10^7 operations
- No chattering or bouncing and no arc generation
- Both slim and flat package available
- SIL (single in line) terminal layout
- Zero-voltage turn-ON and Zero-current turn-OFF for eliminating surge and reducing inrush currents and EMI

TYPICAL APPLICATIONS

- Traffic signal control
- Terminal equipment of data processing
- Computer peripherals
- NC machines
- Automatic ticket punchers

TYPES

1. AQ1 Solid State Relays

Load	Isolation	Zero-cross function	Type	Input voltage	Load current Load voltage	Part No.
AC	Optically coupled isolation	Zero-cross	2 A (Vertical)	3 to 28 V DC	2 A, 75 to 250 V AC	AQ2A2-ZP3/28VDC
			2 A (flat)	3 to 28 V DC	2 A, 75 to 250 V AC	AQ2A2-J-ZP3/28VDC
			5 A	3 to 28 V DC	5 A, 75 to 250 V AC (3 A without heat sink)	AQ5A2-ZP3/28VDC
DC	Optically coupled isolation	-	1 A	3 to 28 V DC	1 A, 10 to 200 V DC	AQ1AD2-3/28VDC
			2 A	3 to 28 V DC	2 A, 3 to 60 V DC	AQ2AD1-3/28VDC

2. Heat sink for AQ1 solid state relay (for 5 A types): AQ-HS-5A

ORDERING INFORMATION

Load current	Load voltage	Shape	Type	Input voltage
1 A 2 A 5 A	2: 75 to 250 V AC D1: 3 to 60 V DC D2: 10 to 200 V DC	Nil: Vertical type J: Flat type	Nil: DC output ZP: AC output (Zero-cross)	3/28 V DC: 3 to 28 V DC

SPECIFICATIONS

Rating (at 20°C 68°F, Ripple factor: less than 1%)

1. AC output type

		Zero-cross		Remarks
		2 A	5 A	
Input side	Input voltage	3 to 28 V DC		
	Input impedance	Approx. 1.6 k Ω (3 to 28 V DC)		
	Drop-out voltage, min.	0.8 V		
Load side	Max. load current	2 A	5 A*	at ambient temperature 40°C 104°F
	Load voltage	75 to 250 V AC		
	Non-repetitive surge current	80 A	100 A	See "REFERENCE DATA 2-(1), (2)" In one cycle at 60 Hz
	Max. "OFF-state" leakage current	5 mA		at 200 V AC 60 Hz
	Max. "ON-state" voltage drop	1.6 V		at Max. carrying current
	Min. load current	50 mA		

*5 A with heat sink 3 A without heat sink see "REFERENCE DATA 1-(2)"

2. DC output type

		1 A type	2 A type	Remarks
		Input side	3 to 28 V DC	
	Input impedance	Approx. 1.6 k Ω		
	Drop-out voltage, min.	0.8 V		
Load side	Max. load current	1 A	2 A	at ambient temperature 40°C 104°F
	Load voltage	10 to 200 V DC	3 to 60 V DC	
	Non-repetitive surge current	5 A (1 s)		
	Max. "OFF-state" leakage current	1 mA		at 200 V AC 60 Hz
	Max. "ON-state" voltage drop	2.3 V	1.6 V	at Max. carrying current
	Min. load current	5 mA		

Characteristics (at 20°C 68°F, Ripple factor: less than 1%)

		AC output		DC output	Remarks
		Zero-cross			
		2 A	5 A		
Operate time, Max.		(1/2 cycle of voltage sine wave) + 1 ms		0.5 ms	
Release time, Max.		(1/2 cycle of voltage sine wave) + 1 ms		2 ms	
Insulation resistance, Min.		100 M Ω for input, output and case		100 M Ω for input, output	at 500 V DC
Breakdown voltage		3,000 Vrms between input and output	3,000 Vrms between input and output 1,500 Vrms among input, output and case	3,000 Vrms between input-output	
Vibration resistance	Destructive	117.6 m/s ² {12G}, 10 to 55 Hz at double amplitude of 2 mm			1 hour for X, Y, Z axis
	Functional	117.6 m/s ² {12G}, 10 to 55 Hz at double amplitude of 2 mm			10 minutes for X, Y, Z axis
Shock resistance	Destructive	Min. 980 m/s ² {100 G}		Min. 980 m/s ² {100 G}	5 times each for X, Y, Z axis
	Functional	Min. 980 m/s ² {100 G}		Min. 980 m/s ² {100 G}	4 times each for X, Y, Z axis
Ambient temperature		-30°C to +80°C -22°F to +176°F			
Storage temperature		-30°C to +100°C -22°F to +212°F			
Operational method		Zero-cross (Turn-ON and Turn-OFF)		—	

AQ1

DIMENSIONS

mm inch

AC output, 2A type (vertical)

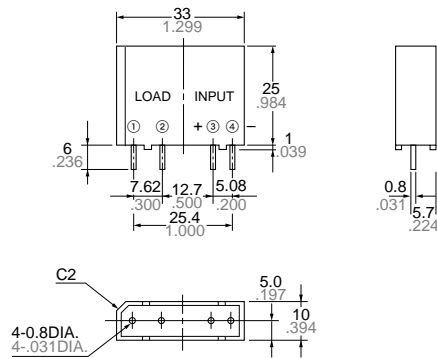

General tolerance: $\pm 0.5 \pm 0.020$

Mounting hole location
(Copper-side view)

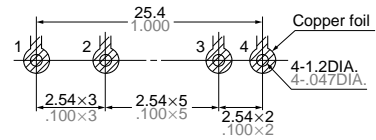

Schematic

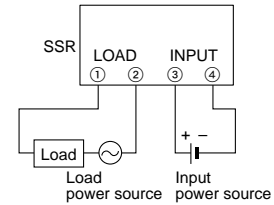

Tolerance: $\pm 0.1 \pm 0.004$

AC output, 2A type (Flat)

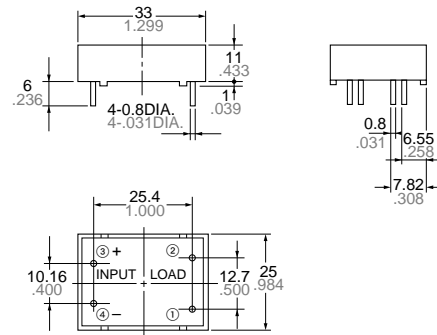

General tolerance: $\pm 0.5 \pm 0.020$

Mounting hole location
(Copper-side view)

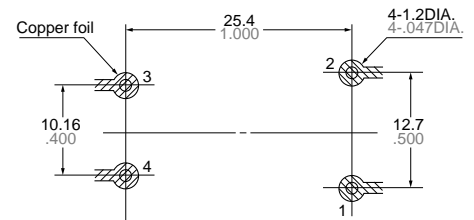

Schematic

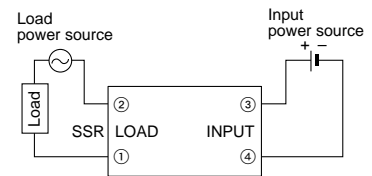

Tolerance: $\pm 0.1 \pm 0.004$

AC output, 5A type

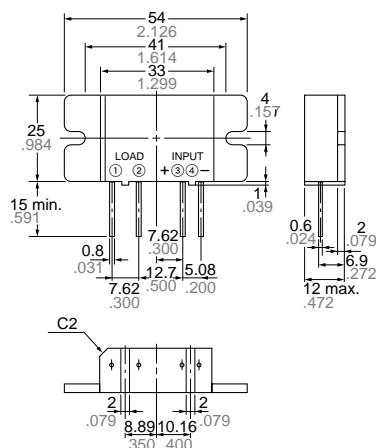

General tolerance: $\pm 0.5 \pm 0.020$

Mounting hole location (Copper-side view)

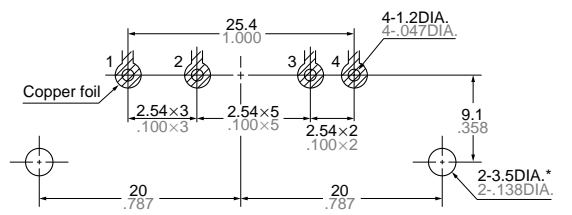

* There 2 holes are not necessary when not using heat sink (AQ-HS-5A)

Schematic

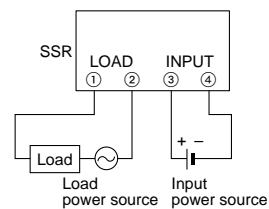

Tolerance: $\pm 0.1 \pm 0.004$

Heat sink (for AC output, 5A type)
AQ-HS-5A

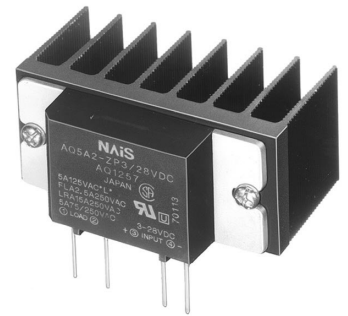
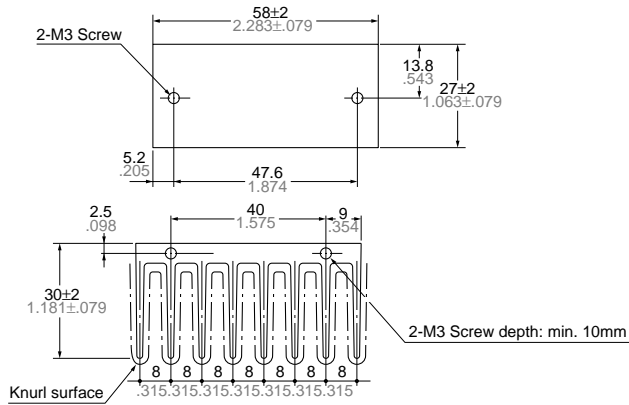

When using heat sink, please refer to "Thermal Design (Page 635)"

General tolerance: $\pm 0.5 \pm 0.20$

DC output, 1A, 2A types

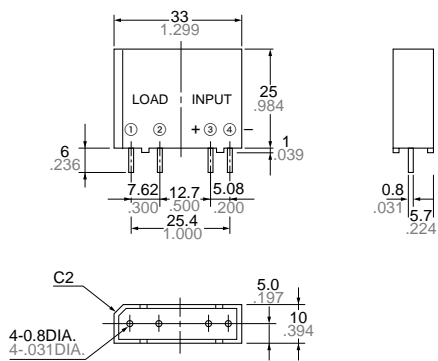
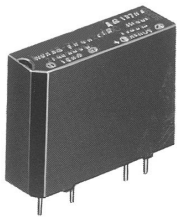

General tolerance: $\pm 0.5 \pm 0.20$

Mounting hole location (Copper-side view)

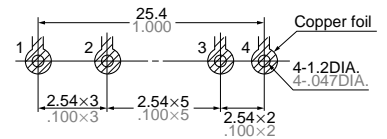

Schematic

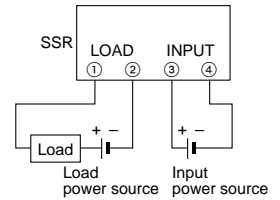

Tolerance: $\pm 0.1 \pm 0.04$

REFERENCE DATA

1. Load current vs. ambient temperature

(1) AC output zero-cross type (2 A type)

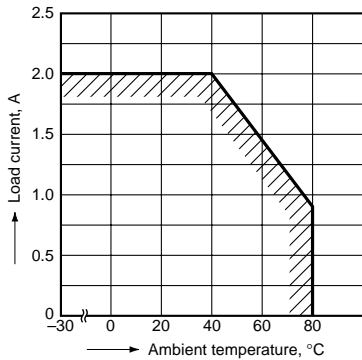

Allowable ambient temperature:
-30°C to +80°C -22°F to +176°F

(2) AC output zero-cross type (5 A type)

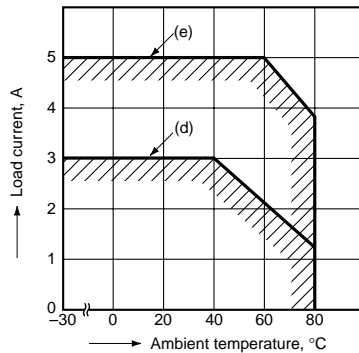

d. External heat sink is not used.
e. In the case of mounting on heat sink (AQ-HS-5A) or 66 × 66 × 2.0 thick aluminum plate. The AQ-HS-5A heat sink is mounted on the printed circuit board. The load current is improved compared with the unmounted condition as indicated in the diagram above. When the 5 A type heat sink (AQ-HS-5A) or a heat sink is not use, in order to provide good cooling conditions, the back surface plate should be exposed.

(3) DC type (1 A, 2 A type)

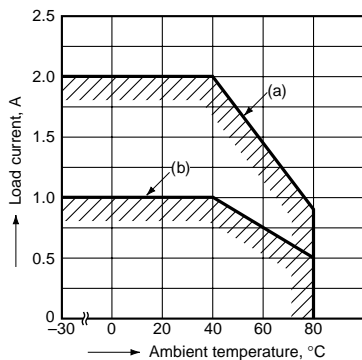

a. DC type (2 A type)

Allowable temperature range:
-30°C to +80°C -22°F to +176°F

b. DC type (1 A type)

Allowable temperature range:
-30°C to +80°C -22°F to +176°F

2. Non-repetitive surge current vs. carrying time

(1) AC output zero-crossing type (2 A type)

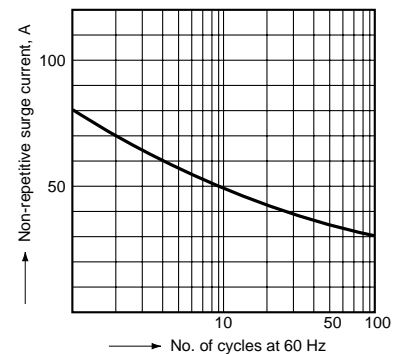

AQ1

2. Non-repetitive surge current vs. carrying time (2) AC output zero-cross type (5 A type)

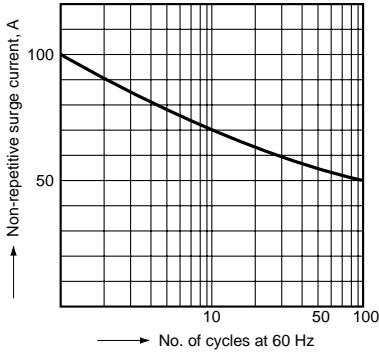

(3) DC output type

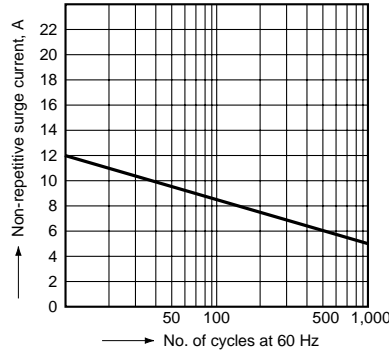

3. Input voltage vs. input current characteristics

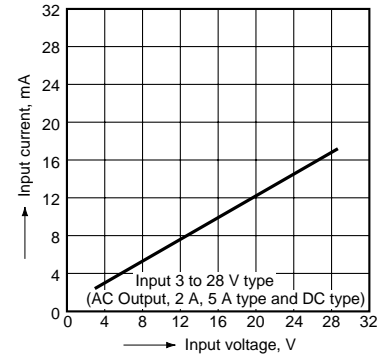

NOTES

1. When using bent output terminals

To avoid applying mechanical stress on the main unit and molded section of the solid state relay, radio pliers should be used to grasp the terminals between the point of bending and the molded case when making the bends.

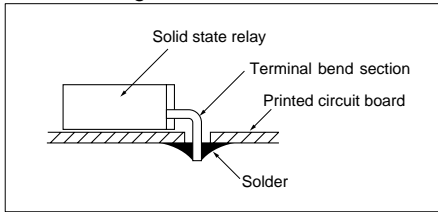

2. When a heat sink is mounted on the 5 A type

The heat sink (AQ-HS-5A) or a heat sink which can make good contact should be used.

If a heat sink is used in which the contact condition is bad, a heat conducting compound should be used to improve the heat radiation. (A silicon compound is a typical example.) The compound should be coated on the heat sink and the AQ1.

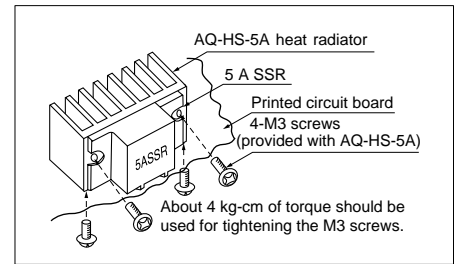

For Cautions for Use, see Page 634 to 637.