

# NAIS

## AQ-F SOLID STATE RELAY

# AQ-F RELAYS

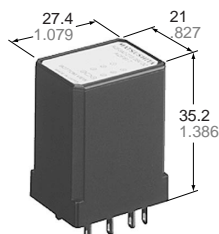

mm inch

### FEATURES

- Suitable for high-capacity and high-frequency switching
- Same size, same terminal arrangement as HC relay  
Sockets for HC relays are applicable
- Two load types available: DC output type (2 A, 3 A)  
AC output type (2 A, 3 A)
- Wide range of input voltage: 3 V to 28 V

### TYPICAL APPLICATIONS

Drive for small-sized motor, heater, solenoid and electromagnetic valves.

- NC machine
- Printing machine
- Machine tool
- Robot for industrial use
- Wrapping and packing machine

### TYPES

	Type	Part No.
AC output	Zero-cross 2 A	AQF2A2-ZT3/28VDC
	Zero-cross 3 A	AQF3A2-ZT3/28VDC
DC output	2 A	AQF2AD1-3/28VDC
	3 A	AQF3AD1-3/28VDC

### SPECIFICATIONS

**Ratings** (at 20°C 68°F, Input voltage ripple: 1% or less)

Item	Type	AC output		DC output		Remarks
		AQF2A2-ZT3/28VDC	AQF3A2-ZT3/28VDC	AQF2AD1-3/28VDC	AQF3AD1-3/28VDC	
Input side	Input voltage	3 to 28 V DC				
	Input impedance	Approx. 1.6 k Ω (3 to 28 V DC)				
	Drop-out voltage, min.	0.8 V DC				
Load side	Max. load current	2 A	3 A	2 A	3 A	See "REFERENCE DATA 1" on the following page
	Load voltage	75 to 250 V AC		3 to 60 V DC		
	Non-repetitive surge current	80 A		5 A	6 A	AC: In one cycle at 60 Hz DC: 1 s
	Max. "OFF-state" leakage current	5 mA		1 mA		AC: at 60 Hz 200 V DC: at 60 V
	Max. "ON-state" voltage drop	1.6 V				at max. carrying current
	Min. load current	50 mA		5 mA		

**Characteristics** (at 20°C 68°F, Input voltage ripple: 1% or less)

Item	Type	AC output		DC output		Remarks
		AQF2A2-ZT3/28 VDC	AQF3A2-ZT3/28 VDC	AQF2AD1-3/28 VDC	AQF3AD1-3/28 VDC	
Operate time max.		(1/2 cycle of voltage sine wave) + 1 ms		0.5 ms		
Release time, max.		(1/2 cycle of voltage sine wave) + 1 ms		2 ms		
Insulation resistance, min.		100 M Ω between input and output				Initial at 500 V DC
Breakdown voltage		2,000 Vrms between input and output				Initial for 1 min.
Vibration resistance	Functional	10 to 55 Hz double amplitude of 3 mm				10 min. for X, Y, Z axes
	Destructive	10 to 55 Hz double amplitude of 3 mm				1 hour for X, Y, Z axes
Shock resistance	Functional	Min. 980 m/s <sup>2</sup> {100 G}				4 times each for X, Y, Z axes
	Destructive	Min. 980 m/s <sup>2</sup> {100 G}				5 times each for X, Y, Z axes
Ambient temperature		-30°C to +80°C -22°F to +176°F				
Storage temperature		-30°C to +100°C -22°F to +212°F				
Operational method		Zero-cross (Turn-ON and Turn-OFF)		—		

# AQ-F

## OPERATING PRINCIPLE

Internal circuit  
AC output type

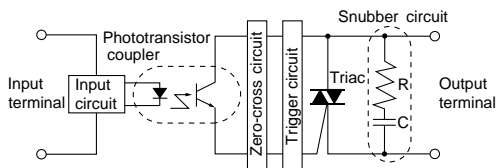

Waveform of input and output (Resistive load)

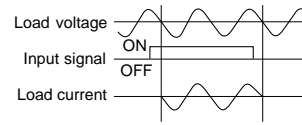

DC output type

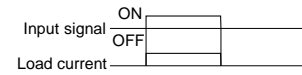
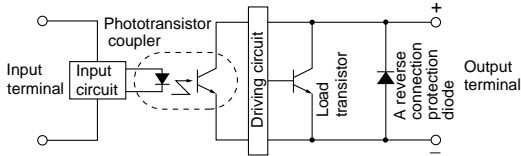

## DIMENSIONS

mm inch

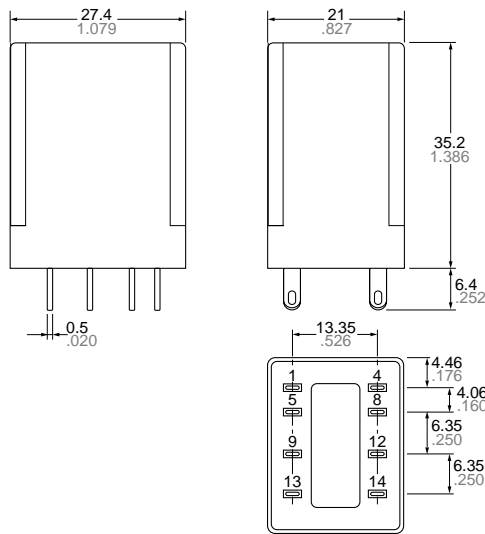

Terminal connection diagram (Bottom view)

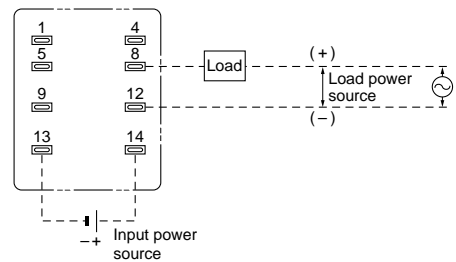

## AQ-F SOLID STATE RELAY ACCESSORIES

Socket of HC relay is available for AQ-F solid state relay.

### 1. Socket for plug-in type

HC2 socket

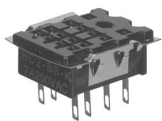

HC2-SS-K

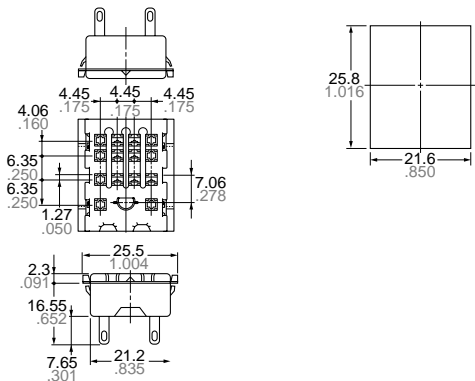
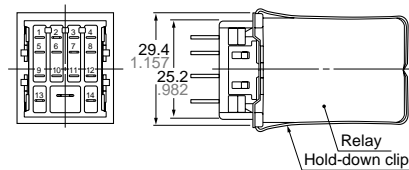

Note: HC3-SS-K and HC4-SS-K can be also used.

Tolerance:  $\pm 0.1 \pm .004$

### 2. Socket for PC board

HC2 socket for PC board

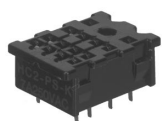

HC2-PS-K

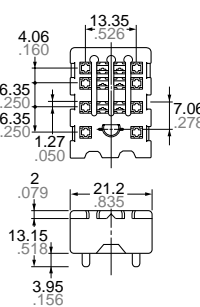
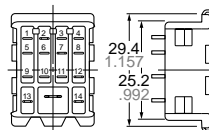

PC board pattern (Bottom view)

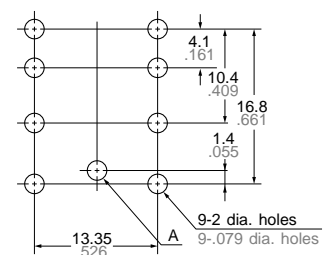

Note: HC3-PS-K and HC4-PS-K can be also used.

Tolerance:  $\pm 0.1 \pm .004$

3. Wrapping socket

Standard wrapping socket

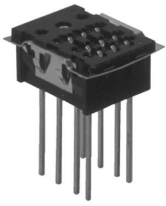

HC2-WS-K

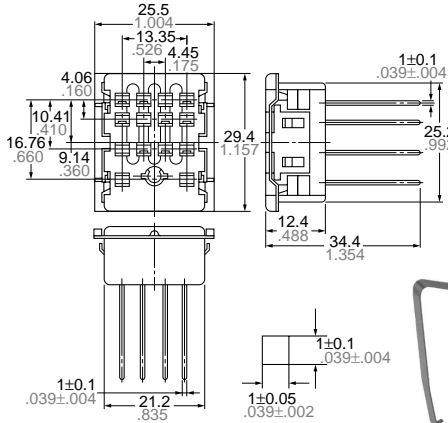

Wrapping socket with lock spring

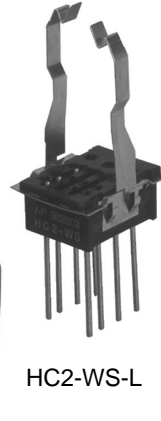

HC2-WS-L

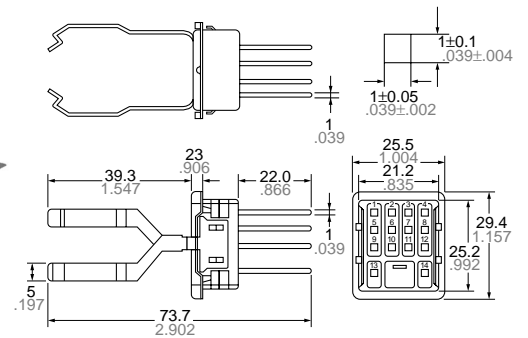

4. DIN rail mounting socket

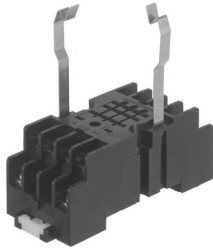

HC2-SFD-K

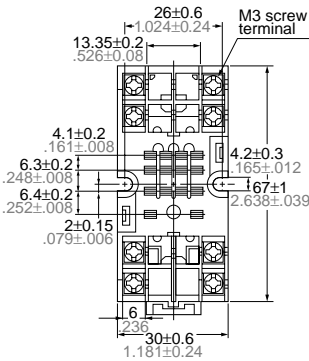

Schematic

Mounting dimension (Bottom view)

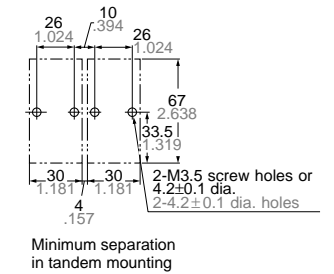
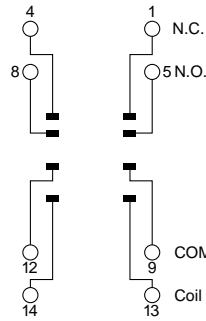

5. DIN socket for HC2-slim type

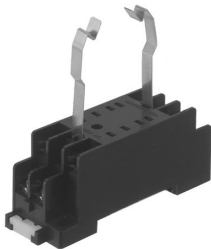

HC2-SFD-S

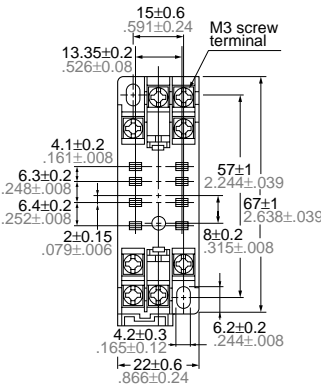

Schematic

Mounting dimension (Bottom view)

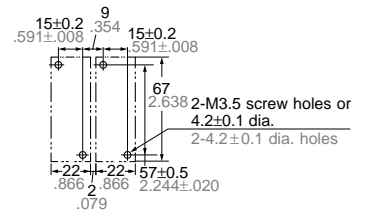
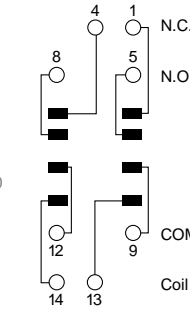

6. General socket

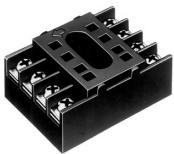

HC2-SF-K

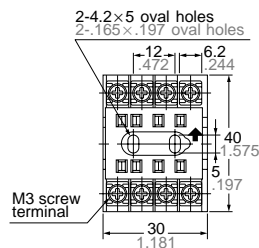

Schematic

Mounting dimension (Bottom view)

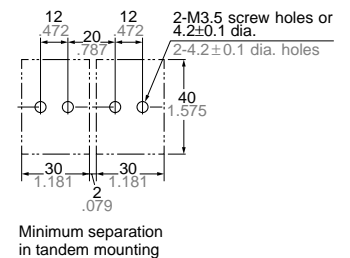

# AQ-F

Mounting rail



AT8-DLA1

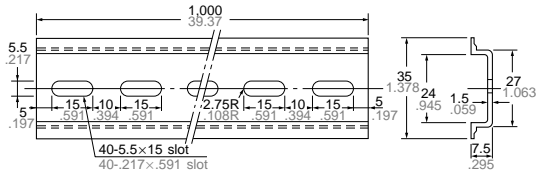

Fastening plate



ATA4806

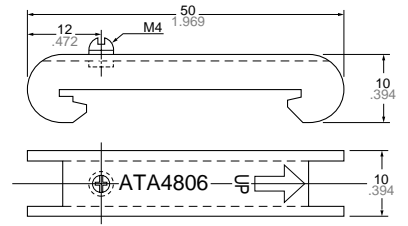

mm inch

## REFERENCE DATA

1. Load current vs. ambient temperature

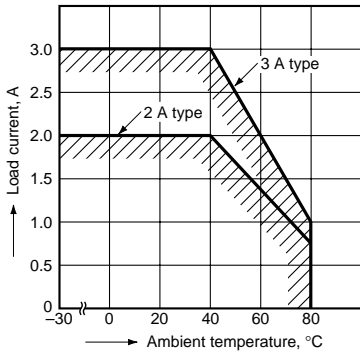

2-(1). Non-repetitive surge current vs. carrying time (AC output type)

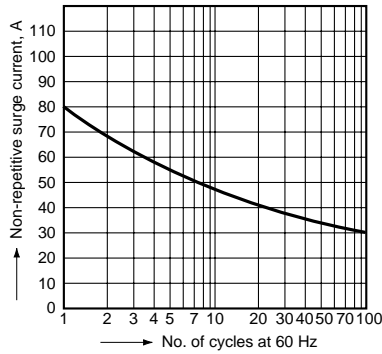

2-(2). Non-repetitive surge current vs. carrying time (DC output type)

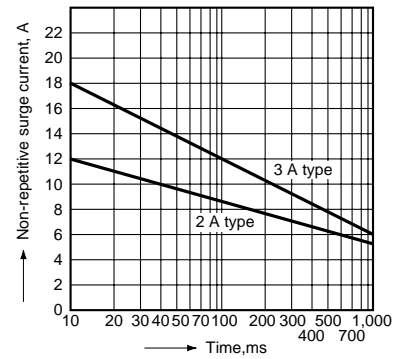

3. Input voltage vs. input current

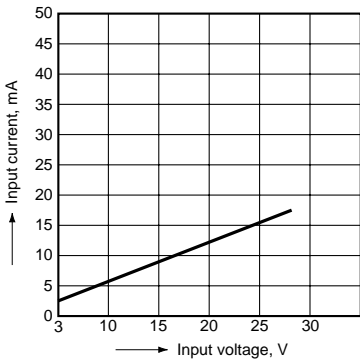

For Cautions for Use, see Page 634 to 637.