

mm inch

FEATURES

- Input and output modules for interfacing between CPU and external input devices or loads
 - IAC: AC input (yellow)
 - OAC: AC output (black)
 - IDC: DC input (white)
 - ODC: DC output (red)
- Excellent transient noise immunity
- Breakdown voltage: 4,000 V between input and output
- Zero-cross switching for reducing EMI
- LED operation indication types available

TYPICAL APPLICATIONS

1. Optimum for minicomputer and microcomputer use, and for feed back control process control systems. Robot, NC machine, Automatic Assembling machine.
2. Programmable controllers controls for motors, solenoids and solenoid valves.

EXAMPLE OF I/O SYSTEM CONSTRUCTION

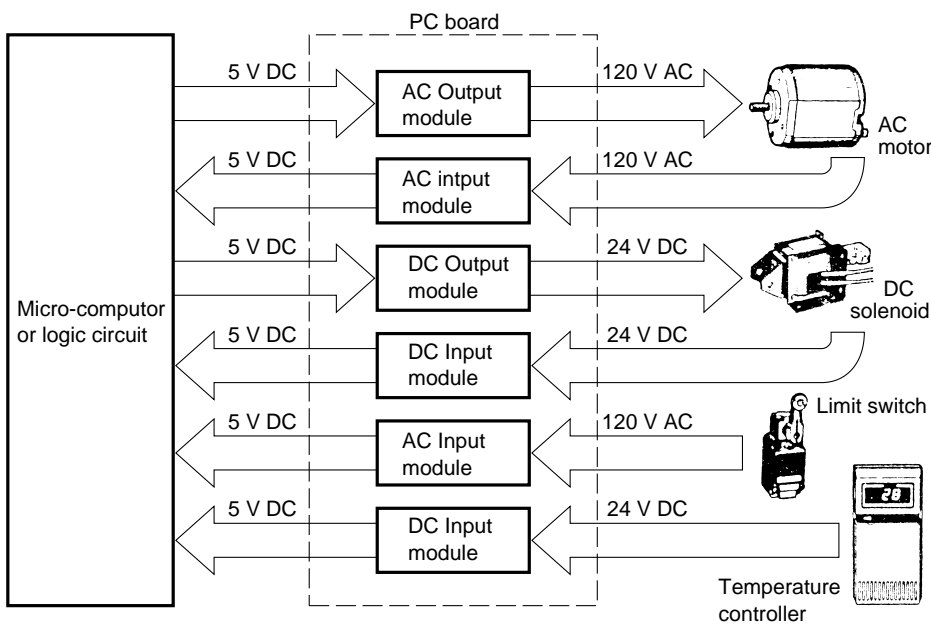

Recently, the microcomputer shown in the left has come into use, with a rapid increase in the use of feedback control for process controllers. As an input/output interface relay, it represents a fast responding interface with long life, noiseless, PC board mounting facility, making circuit design and manufacture simple, and providing amplification of maintenance with space saving. Our company's I/O relays have been grouped for use with either AC or DC devices as AC output type, AC input type, DC output type, and DC input. In addition, the I/O use relay is modularized identically, responding to the various load types for PC board mounting. Because combinations can be freely used, circuit design has been greatly facilitated. Accordingly, the above diagram of interface PC board mounting is a practical construction which can be used.

ORDERING INFORMATION

Input or Output	AC or DC	Logic supply or control voltage	Input or Output Voltage		Operation indication	
			Input	Output		
I: Input module O: Output module	AC: AC input or AC output DC: DC input or DC output	3/15: 3 to 15 V DC 4/15: 4 to 15 V DC 10/32: 10 to 32 V DC	Nil	80 to 140 V AC 3 to 32 C DC	75 to 125 V AC 3 to 60 V DC	Nil: No operation indication L: Operation indication
			A	160 to 280 V AC	75 to 250 V AC 10 to 200 V DC	

(Note) Standard packing: Carton: 20 pcs.; Case: 200 pcs.

TYPES

Input modules

Type	Logic supply voltage	Input voltage	Part No.	
			No LED	With LED
AC	4 to 15 V DC	80 to 140 V AC	IAC4/15	IAC4/15-L
		160 to 280 V AC	IAC4/15-A	IAC4/15-AL
	10 to 32 V DC	80 to 140 V AC	IAC10/32	IAC10/32-L
		160 to 280 V AC	IAC 10/32-A	IAC10/32-AL
DC	4 to 15 V DC	3 to 32 V DC	IDC4/15	IDC4/15-L
	10 to 32 V DC	3 to 32 V DC	IDC10/32	IDC10/32-L

Output modules

Type	Logic supply voltage	Output voltage	Part No.	
			No LED	With LED
AC	3 to 15 V DC or 4 to 15 V DC	75 to 125 V AC	OAC3/15	OAC4/15-L
		75 to 250 V AC	OAC3/15-A	OAC4/15-AL
	10 to 32 V DC	75 to 125 V AC	OAC10/32	OAC10/32-L
		75 to 250 V AC	OAC10/32-A	OAC10/32-AL
DC	3 to 15 V DC or 4 to 15 V DC	3 to 60 V DC	ODC3/15	ODC4/15-L
		10 to 200 V DC	ODC3/15-A	ODC4/15-AL
	10 to 32 V DC	3 to 60 V DC	ODC10/32	ODC10/32-L
		10 to 200 V DC	ODC10/32-A	ODC10/32-AL

SPECIFICATIONS

Rating (at 20°C 68°F, Voltage ripple of logic side: less than 1%)

1. Input module

		IAC 4/15	IAC 4/15-L	IAC 10/32	IAC 10/32-L	IAC 4/15-A	IAC 4/15-AL	IAC 10/32-A	IAC 10/32-AL	IDC 4/15	IDC 4/15-L	IDC 10/32	IDC 10/32-L
Input side	Input voltage	80 to 140 V AC				160 to 280 V AC				3 to 32 V DC			
	Input current, Max.	5 mA (100 V)				5 mA (200 V)				20 mA (32 V)			
	Operate voltage, Max.	80 V AC				160 V AC				3 V			
	Release voltage Min.	10 V AC				20 V AC				0.8 V			
Logic side	Logic supply voltage	4 to 15 V		10 to 32 V		4 to 15 V		10 to 32 V		4 to 15 V		10 to 32 V	
	Logic supply current, Max.	15 mA											
	Breakdown voltage	30 V											
	Output current, Max.	25 mA											
	Max. "OFF-side" leakage current	100 µA											
Max. "ON-side" voltage drop	0.4 V												

2. Output module

		OAC 3/15	OAC 4/15-L	OAC 10/32	OAC 10/32-L	OAC 3/15-A	OAC 4/15-AL	OAC 10/32-A	OAC 10/32-AL	ODC 3/15	ODC 4/15-L	ODC 10/32	ODC 10/32-L	ODC 3/15-A	ODC 4/15-AL	ODC 10/32-A	ODC 10/32-AL
Logic side	Logic voltage range	3 to 15 V	4 to 15 V	10 to 32 V		3 to 15 V	4 to 15 V	10 to 32 V		3 to 15 V	4 to 15 V	10 to 32 V		3 to 15 V	4 to 15 V	10 to 32 V	
	Input Impedance (Approx.)	1.6 kΩ	1.7 kΩ	6 kΩ	5 kΩ	1.6 kΩ	1.7 kΩ	6 kΩ	5 kΩ	1.6 kΩ	1.7 kΩ	6 kΩ	5 kΩ	1.6 kΩ	1.7 kΩ	6 kΩ	5 kΩ
	Drop-out voltage, Min.	0.8V															
Output side	Max. load current	2 A (Ambient temperature: Max. 30°C)								2 A (Ambient temperature: Max. 40°C)				1 A (Ambient temperature: Max. 40°C)			
	Output voltage	75 to 125 V AC				75 to 250 V AC				3 to 60 V DC				10 to 200 V DC			
	Non-repetitive surge current	30 A (in one cycle at 60 Hz)								5 A (for 1 s)							
	Max. "OFF-state" leakage current	5 mA (100 V)				5 mA (200 V)				1 mA (60 V)				1 mA (200 V)			
	Max. "ON-state" voltage current	1.6 V								1.6 V				2.3 V			
	Min. load current	50 mA								5 mA							

Characteristics (at 20°C 68°F, Voltage ripple of logic side: less than 1%)

		Input modules				Output modules				
		IAC		IDC		OAC		ODC		
Operate time, max.		20 ms		5 ms		(1/2 cycle of voltage sine wave)+1 ms		0.5 ms		
Release time, max.		20 ms		5 ms		(1/2 cycle of voltage sine wave)+1 ms		2 ms		
Insulation resistance		10 ⁹ Ω between input and output (at 500 V DC)								
Breakdown voltage		4,000 V AC between input and output								
Vibration resistance	Functional	117.6 mm/s ² {12G}, 10 to 55 Hz at double amplitude of 2 mm (10 minutes for X, Y, Z axis)								
	Destructive	117.6 mm/s ² {12G}, 10 to 55 Hz at double amplitude of 2 mm (1hour for X, Y, Z axis)								
Shock resistance	Functional	Min. 980 m/s ² {100G} (4 times each for X, Y, Z axis)								
	Destructive	Min. 980 m/s ² {100G}(5 times each for X, Y, Z axis)								
Ambient temperature		-30°C to +80°C -22°F to +176°F				-30°C to +80°C -22°F to +176°F				
Storage temperature		-30°C to +100°C -22°F to +212°F				-30°C to +100°C -22°F to +212°F				
Operational method		-				Zero-cross (Turn-ON and Turn-OFF)				-

DIMENSIONS

Input module (IAC, IDC)

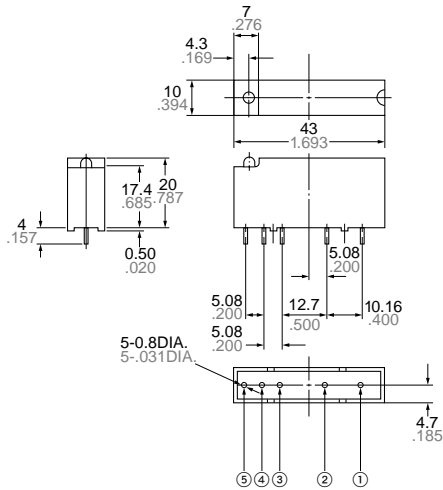

PC board pattern (Copper-side view)

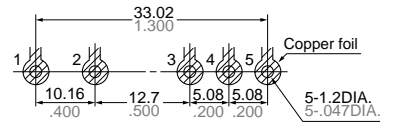

	IAC	IDC
①	Input: AC	Input: DC +
②	Input: AC	Input: DC -
③	Vcc	Vcc
④	Logic output	Logic output
⑤	Grounding	Grounding
Body color	Yellow	White

Output modules (OAC, ODC)

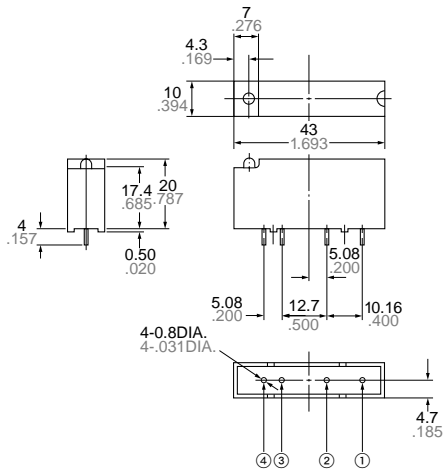

PC board pattern (Copper-side view)

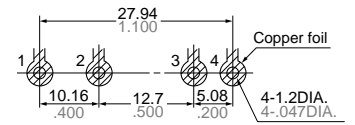

	OAC	ODC
①	Output: AC	Output: DC +
②	Output: AC	Output: DC -
③	Input: DC+	Input: DC+
④	Input: DC-	Input: DC-
Body color	Black	Red

REFERENCE DATA

1-1. Load current vs. ambient temperature (OAC)

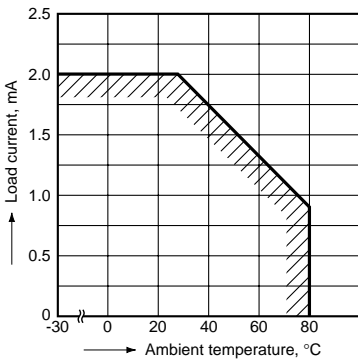

1-2. Load current vs. ambient temperature (ODC)

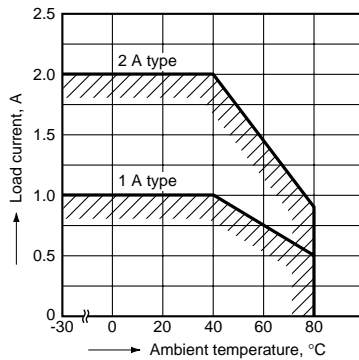

2-1. Surge current and time (OAC)

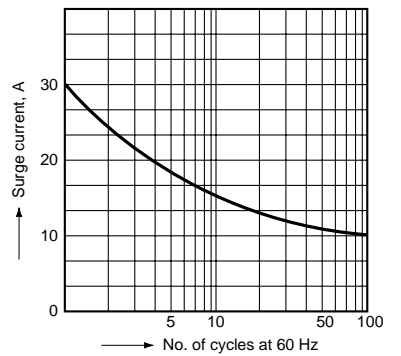

2-2. Surge current and time (IDC)

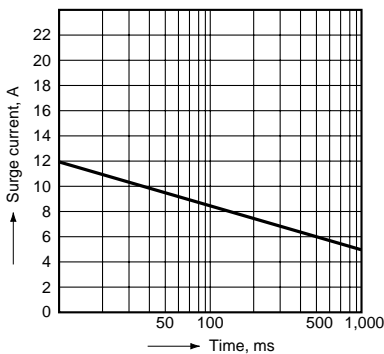

3. Input voltage and current (OAC, ODC)

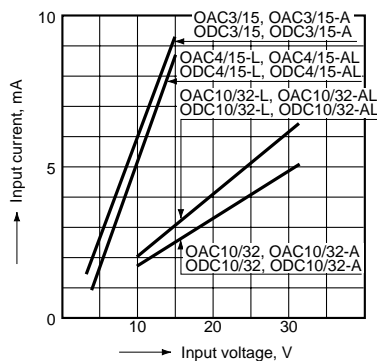

BLOCK DIAGRAM

IAC without LED

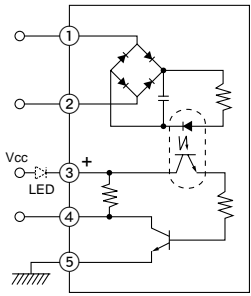

IAC with LED

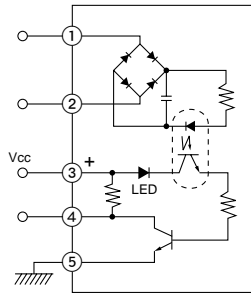

IDC without LED

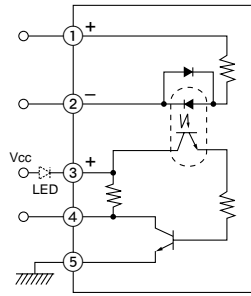

IDC with LED

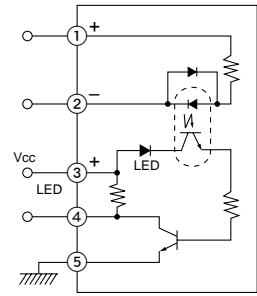

OAC without LED

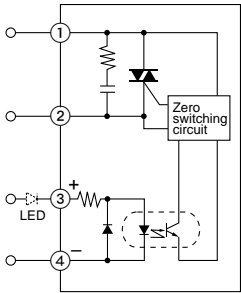

OAC with LED

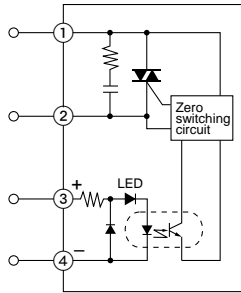

ODC without LED

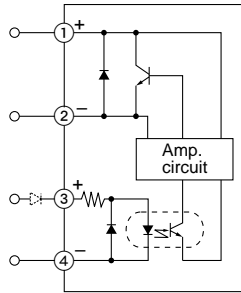

ODC with LED

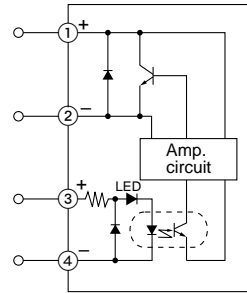

Wiring method

(8 input/output example)

Wiring can be used commonly for input modules and output modules. Therefore, wiring becomes simple.

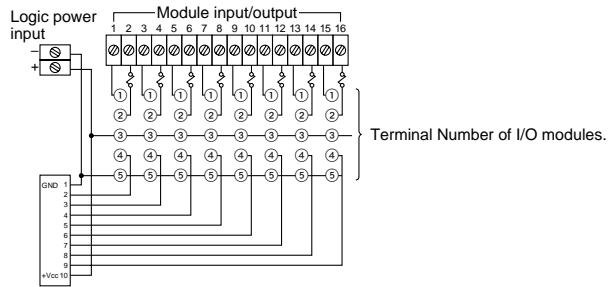

For Cautions for Use, see Page 634 to 637.